



Management
System
ISO 9001:2008

www.tuv.com
ID 9105067711

**Kotao
na BIOMASU/
BIOMASS boiler**

**SERIJA TKAN Integra /
TKAN Integra SERIES
80-300kW**

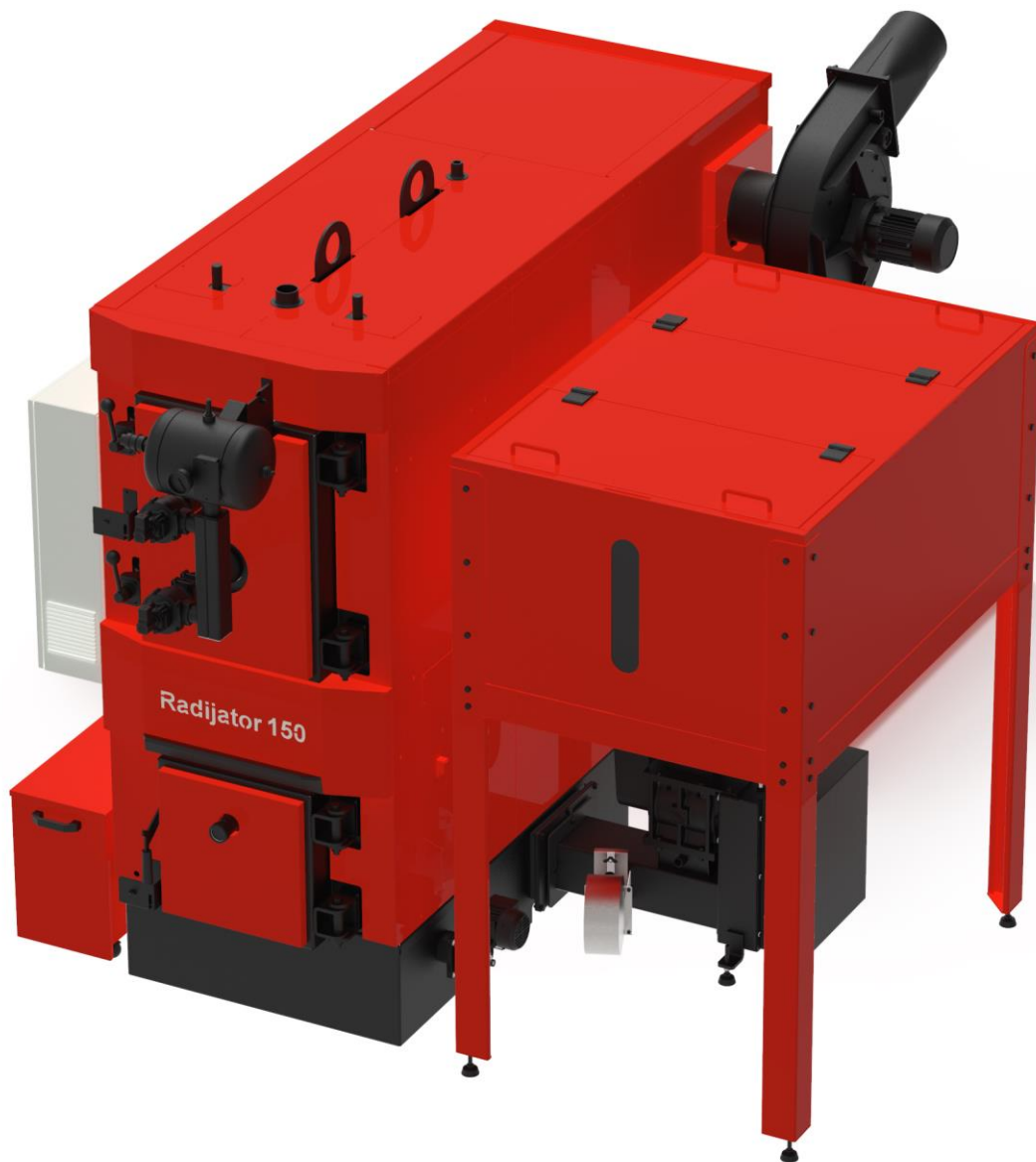

INSTRUKCIJE / INSTRUCTION MANUAL

Montaža, korišćenje i održavanje kotla / *Assembly, use and maintenance of heating boiler*

Sadržaj

1. Upozorenja	3
1.1. Opšta upozorenja	3
1.2. Važna upozorenja	3
1.3. Minimalna udaljenost od zapaljivih materijala	4
2. Opis kotla	5
2.1. Konstrukcija	5
2.2. Otprašivanje odnosno automatsko čišćenje cevnog snopa izmenjivača.....	6
2.3. Ciklon	6
3. Montaža.....	9
3.1. Opšta upozorenja	9
3.2. Kotlarnica	10
3.3. Priključenje na dimnjak	12
3.4. Otprašivanje.....	14
3.5. Montaža multiciklona.....	16
4. Presek TKAN Integra kotla sa opisom elemenata	18
5. Tabela sa dimenzijama.....	21
6. Hidraulična šema.....	22
7. Objašnjenje rada automatike TKAN	23
7.1. Displej automatike	24
7.2. Start rada kotla na biomasu	31
7.3. Kratko uputstvo za upotrebu automatike	34
7.3.1. Dopuna ložišta sa peletom, priprema za paljenje i start potpale na pelet.....	34
7.3.2. Promena vremena doziranja transportera u radnom režimu.....	35
7.3.3. Promena jačine ventilatora u radnom režimu	35
7.3.4. Promena zadate temperature vode u kotlu.....	36
7.3.5. Kako očitati temperaturu dimovodnih gasova.....	37
7.4. Greške prilikom startovanja kotla	37
8. Održavanje kotla	41
9. Garancija.....	43

1. Upozorenja

1.1. Opšta upozorenja

- Nakon uklonjenog pakovanja uveriti se u kompletnost isporuke, i u slučaju nedostataka, obratiti se prodavcu koji je prodao kotao.
- Kotao mora biti upotrebljen isključivo za namenu koju je predvideo proizvođač. Isključuje se bilo kakva odgovornost od strane proizvođača za štetu uzrokovanu osobama, životinjama ili stvarima, u slučaju grešaka pri montaži, regulaciji, održavanju ili nepravilnom korišćenju.
- U slučaju curenja vode isključiti uređaj sa električnog napajanja, zatvoriti napajanje vodom i obavestiti ovlašćeni servis ili ovlašćenog montera.
- Ovo uputstvo je sastavni deo uređaja i mora se čuvati sa pažnjom i mora **UVEK** pratiti uređaj i u slučaju promene vlasnika ili korisnika ili u slučaju priključenja na drugu instalaciju. U slučaju oštećenja ili nestanka tražiti novi primerak od ovlašćenog prodavca.

1.2 . Važna upozorenja

Podsećamo da korišćenje uređaja na biomasu i čvrsto gorivo i koji imaju kontakt sa električnom energijom i vodom zahtevaju poštovanje sigurnosnih mera i to:

- ⚠ Zabranjeno je korišćenje kotla od strane dece i osoba sa ograničenim mogućnostima bez pratnje.
- ⚠ Zabranjeno je korišćenje kotla na instalacijama sa radnom temperaturom većom od 90°C i radnim pritiskom većim od 3 bara.
- ⚠ Zabranjeno je korišćenje lako zapaljivih goriva (alkohol, nafta) radi bržeg paljenja drveta.
- ⚠ Zabranjeno je odlaganje lako zapaljivih materijala u blizini kotla i u blizini vrata za loženje. Pepeo se mora odlagati u zatvorene i nezapaljive spremnike.
- ⚠ Zabranjeno je spaljivanje otpada i materijala čije sagorevanje prouzrokuje plamen ili opasnost od eksplozije (npr. plastične kese, piljevinu, ugljenu prašinu, blato itd.).
- ⚠ Zabranjena je bilo kakva intervencija tehničkog lica ili čišćenje pre nego se kotao isključi sa električnog napajanja i to tako što se utičnica izvadi sa priključka elektro-mreže.
- ⚠ Zabranjena je izmena na sigurnosnim elementima. Obavezan je periodični pregled sigurnosnih elemenata u skladu sa zakonima države u kojoj je kotao namontiran.
- ⚠ Zabranjeno je zatvaranje ventilacionih otvora na prostoriji u kojoj se nalazi kotao. Ventilacioni otvori su neophodni za pravilno sagorevanje.
- ⚠ Zabranjeno je izlaganje kotla atmosferskim nepravilnostima. Sam kotao nije predviđen za spoljnu montažu i ne sadrži sistem protiv smrzavanja.
- ⚠ Zabranjeno je isključivanje kotla ukoliko spoljna temperatura može da padne ispod NULE (opasnost od smrzavanja).

- ⚠ Za elektronapajanje velikih industrijskih kotlova serije TKAN koristi se trofazna el. energija. Ukoliko korisnik koristi agregate koji se uključuju kada nestane struje, obavezan je da proveri da u toj situaciji **el. motori za transport peleta imaju isti smer** kao i kada su na mrežnom napajanju. Ukoliko motori rade sa suprotnim smerom može doći do velikih oštećenja na kotlu.

1.3. Minimalna udaljenost od zapaljivih materijala

- Obezbedite odgovarajuću udaljenost od zapaljivih materijala, ako je potrebno obezbediti zaštitu istih.
- Minimalna udaljenost od zapaljivih materijala je propisana zakonom- molimo da se o tome raspitate kod stručnih lica, koja se bave grejanjem, i dimničara.
- Minimalna udaljenost kotla i cevi za odvod dimnih gasova od slabo i prosečno gorivih materijala treba da bude najmanje 100mm.
- Minimalno rastojanje od lako zapaljivih materijala je 200mm, a isto važi i za materijale čija zapaljivost nije poznata.

Opasnost od požara!

- Skladištenje zapaljivih materijala i tečnosti u blizini kotla je zabranjeno.
- Obavezno upozorite korisnike o potrebnoj minimalnoj udaljenosti zapaljivih materijala od kotla.

Zapaljivost građevinskih materijala	
A ... nezapaljivi	azbest, kamen, građevinski kamen, keramičke zidne pločice, terakota, malter, cementna glazura (bez organskih dodataka)
B ... koji nisu lako zapaljivi	gipsane kartonske ploče, staklena vlakna, ploče od AKUMINA, IZOMINA, RAJOLITA, LIGNOSA, VELOKSA i HERAKLITA
C1 ... slabo gorivi	bukovo i hrastovo drvo, kompozitno drvo, filc, ploče od HOBREKSA, VERZALITA, UMAKARTA
C2 ... prosečno gorivi	drvo bora, tise i jele, kompozitni materijali
C3 ... lako zapaljivi	Asfalt, karton, celulozni materijali, iverica, pluta, poliuretani, polistiren, polipropilen, polietilen, podna vlakna

2.Opis kotla

Kotao **TKAN Integra** je razvijen sa ciljem da **RADIJATOR INŽENJERING** ponudi tržištu kotao koji je po svojim mehaničkim i termičkim osobinama izrazito namenjen biomasi kao gorivu.

Koristeći uopšteni pojam „BIOMASA“ pre svega se misli na pelet, ali treba istaći i mogućnost loženja sa košticama voća i to pre svega višnja, trešnja. **Ukoliko korisnik želi da koristi neki oblik biomase koji nije naveden, obavezno treba da kontaktira službu konstrukcije i razvoja Radijator Inženjering-a ili ovlašćenog prodavca, jer pojedini oblici biomase zahtevaju posebna, specifična rešenja sagorevanja.** Prilikom korišćenja navedenih goriva podrazumeva se automatska kontrola glavnih parametara rada. U svim navedenim primerima korišćenja biomase zahteva se određen stepen suvoće goriva.

Seriya industrijskih kotlova **TKAN Integra** proizvodi se u sledećim snagama: **TKAN 80 Integra, TKAN 100 Integra, TKAN 150 Integra, TKAN 200 Integra, TKAN 250 Integra i TKAN 300 Integra.**

2.1. Konstrukcija

Po spoljašnjem dizajnu, dimenzijama ložišta, otvorima za loženje i čišćenje **TKAN Integra** je zadržao sve dobre osobine predhodnih modela po kojima je **RADIJATOR INŽENJERING** prepoznatljiv na tržištu uz nova savremena rešenja koja omogućavaju minimalnu emisiju štetnih gasova, produženi rad vek i automatizovan rada kotla na višem nivou.

Vodeni deo kotla, njegov način izmene toplote između dimnih gasova i vode putem cevnog izmenjivača, prilagođen je biomasi. Zbog primene ventilatora, tj. prinudne promaje put dimnih gasova duži je nego kod standardnih kotlova. Iz istih razloga moguća je primena usmerivača dimnih gasova tzv. turbulatora koji dodatno povećavaju stepen iskorišćenja kotla. Turbulatori su spirale napravljene od šipkastog materijala.

Stepen korisnosti na pelet je preko 90%. Vrednosti dimnih gasova mogu u svakom trenutku da se očitaju na displeju automatike (više u delu 7.4.7. Kako očitati temperaturu dimnih gasova).

Industrijski **TKAN** kotlovi **poseduju** izmenjivač od bešavnih cevi za montažu **ventila za termičko osiguranje oticanjem**. Svi delovi vodenog dela kotla izrađeni su od bešavnih cevi kvaliteta **ST 35.4** i kotlovskog lima koji su kvaliteta **1.0425 EU** standard odnosno **P265GH** standard **EUII**.

Ložište je po svojem principu rada tzv. „izviruće“, gde gorivo iz zone transporta ide vertikalno uvis tj. izvire do zone sagorevanja. Napravljeno je od masivnih izolacijskih materijala i sivog liva i sa unutrašnje strane je ozidanom opekam.



Potrebno je povremeno i ručno očistiti prostor oko ložišta.

Prednosti ozidanih kotlova u odnosu na neozidane su sledeće:

- emisije štetnih gasova su minimalne;
- smanjena emisija prašine;
- iskorišćenje goriva je maksimalno;
- radni vek kotla se produžava jer lim nije direktno izložen plamenu.

Transport goriva obezbeđen je pužnim transporterima. Gorivo dolazi iz silosa zapremine od 457 L pa do 1610 L u zavisnosti od veličine kotla.

U slučaju potrebe vrlo je lako, demontirati ceo sklop u tri nezavisne celine: silos, mehanizam za nalaganje, kotao sa ložištem.

Kada govorimo o ložištu treba napomenuti da kotlovi serije TKAN Integra imaju podsklop namenjen za AUTOMATSKO ČIŠĆENJE PROSTORA OKO LOŽIŠTA KOTLA. Kotlovi serije TKAN Integra poseduju jednu pužnu osovinu sa motorom za čišćenje pepela iz ložišta što je prikazano na Slici 1.

2.2. Otprašivanje odnosno automatsko čišćenje cevnog snopa izmenjivača

 **Modeli TKAN 80 Integra i TKAN 100 Integra nemaju integrisan sistem za otprašivanje.**

Čišćenje izmenjivača je automatsko i to putem komprimovanog vazduha. Otprašivanje kotla podrazumeva automatsko čišćenje kotla od čađi upotrebom komprimovanog vazduha. Ceo sistem se sastoji od: kompresorske jedinice, rezervoara vazduha i otprašivačke jedinice. Princip rada je zasnovan na brzom ubacivanju komprimovanog vazduha kroz otvore na vratima da bi se dimovodne cevi očistile od čađi. Automatsko uključivanje pulsnih ventila je fabrički podešeno i uključuje se jedan po jedan u određenom vremenskim intervalima. Ugrađen je i mikroprekidač na gornjim vratima koji će u slučaju otvaranja gornjih vrata momentalno prekinuti funkciju otprašivanja. Posle zatvaranja gornjih vrata, aktivira se mikroprekidač i uključuje se automatsko otprašivanje.

 **Naravno pored automatskog čišćenja potrebno je povremeno ručno očistiti izmenjivač.**

2.3. Ciklon

 **Da bi ispuštanje čestica prašine iz dimnih gasova bilo minimalno kod modela TKAN 80 Integra i TKAN 100 Integra ugrađen je ventilator na dimnjači, dok je kod modela TKAN 150 Integra, TKAN 200 Integra, TKAN 250 Integra i TKAN 300 Integra konstruisan je multiciklon sa centrifugalnim ventilatorom.**

 **Povremeno je potrebno očistiti i ciklon kroz odgovarajuće revizione otvore.**

Multiciklona sa centrifugalnim ventilatorom može smanjiti i potrebnu visinu dimnjaka. Multiciklon je skup više ciklona malog prečnika koji se postavljaju na zajedničko kućište. Dimni gasovi se uvode tangencijalno pri vrhu cilindričnog dela ciklona, pri čemu usled delovanja centrifugalne sile nastaje odvajanje čestica iz gasa, koje dospevaju do zida ciklona. Delovanjem sile težine odvojene čestice se spiralno spuštaju niz kupasti deo ciklona u kontejner. Očišćena struja gasa spiralno ističe kroz uronjenu cev ciklona u atmosferi ili sistem cevovoda. Na **Slici 7** su prikazani osnovni delovi multiciklona: kućište, telo i kontejner.

Veoma važna napomena u vezi konstrukcije TKAN industrijskih kotlova je da ona omogućuje i dodatnu opremu. Dodatna oprema se naručuje pre isporuke kotla.

Elementi dodatne opreme su:

Veći dnevni silosi koji su uz kotao. Standardni silosi (**Slika 2**) su navedeni u tabeli sa dimenzijama, međutim ako kupac ima prostora u kotlarnici i želi veći tzv. dnevni silos prema posebnim dimenzijama, moguće je takav naručiti u proizvodnji Radijator Inženjeringa. Isporuka ovakvog silosa moguća je i naknadno kad je kotao već u kotlarnici.

Višednevni magacini za pelet. Moguće je isporučiti i silose koji su kapaciteta i nekoliko desetina tona i koji su pužnim transportnim sistemom povezani sa malim dnevnim silosom. Punjenje ovakvih silosa vrši se iz tzv. džambo vreća od jedne tone kofičastim elevatorom. Ovu opremu takođe je moguće naknadno isporučiti.

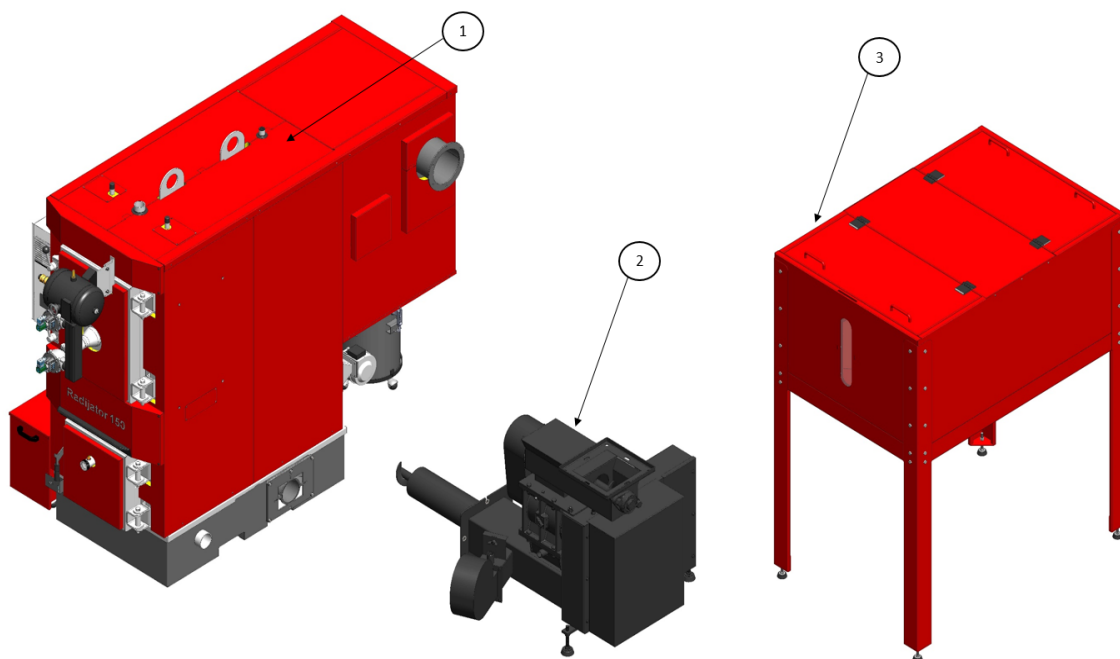

Slika 1. Prikaz demontažnih celina kotla

1. Kotao
2. Sklop dozera
3. Silos

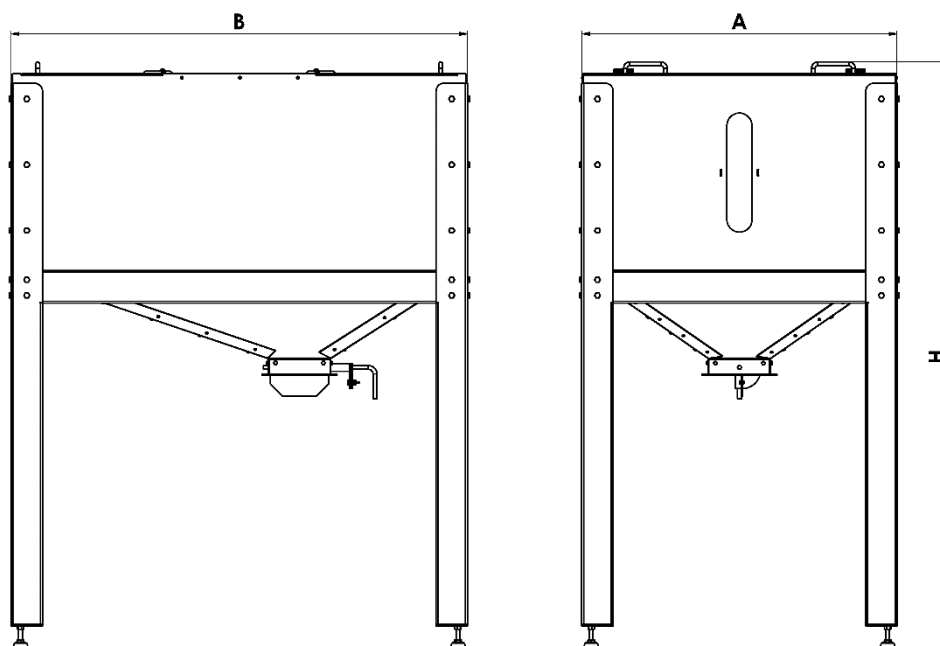

Slika 2. Standardni silos za TKAN-kotlove

	DIMENZIJE				Količina peleta koja staje u silosu
	A	B	H	V	
	mm			liters	
<i>TKAN 80 Integra</i>	606	1020	1736	290	180
<i>TKAN 100 Integra</i>	1006	1456	1872	680	410
<i>TKAN 150 Integra</i>	1006	1456	1872	680	410
<i>TKAN Integra 200/250/300</i>	1394	1830	1822	1600	1000
	1394	1830	2130	2330	1500
	1394	1830	2445	3115	2000

Tabela 1. Dimenzije silosa

Kod kotlova TKAN Integra 200/250/300 postoji mogućnost da se u kotlarnici ugradi jedna od tri varijante silosa, naravno po želji kupca. Gabaritne mere tih silosa prikazane su u tabeli 1.

3. Montaža

3.1. Opšta upozorenja



Pre puštanja kotla u rad proveriti da li je smer motora mehanizma za transport peleta takav da obezbeđuje dotok peleta u ložište. Takođe, ako se u slučaju nestanka el. energije koriste agregati proveriti da li je smer motora takav da pelet ide u prostor za loženje. U suprotnom može doći do trajnih oštećenja na kotlu.



Kotlovi TKAN su predviđeni za maksimalni radni pritisak od 3 bara i maksimalnu radnu temperaturu od 90 stepeni celzijusa, dakle oni spadaju u kategoriju toplovodnih kotlova. Rad kotla na većim vrednostima od navedenih može da dovede do velikih materijalnih šteta i ugrožavanja ljudskih života.



Strogo je zabranjeno reduciranje poprečnih preseka sigurnosnih vodova. Takođe, strogo je zabranjeno instaliranje sigurnosne opreme čiji je radni pritisak veći od 3 bara. Preporučuje se ugradnja ventila za termičko osiguranje oticanjem i to u skladu sa zakonom države u kojoj se oprema instalira.



Kotao je sa ventilatorom, automatikom, mehanizmom za transport peleta, eventualno i sa mehanizmom za čišćenje ložišta ili cevnog snopa. Svi ovi uređaji koriste napajanje 230V ili 3x 380V, tako da nepravilno instaliranje i neoprezno rukovanje mogu da ugroze ljudski život strujnim udarom.



Pre puštanja kotla u rad proveriti da li je smer motora mehanizma za transport peleta takav da obezbeđuje dotok peleta u ložište. Takođe, ako se u slučaju nestanka el. energije koriste agregati proveriti da li je smer motora takav da pelet ide u prostor za loženje. U suprotnom može doći do trajnih oštećenja na kotlu.



Prilikom svake intervencije na elektro sistemu kotla (npr. promena elektro grejača zapotpalu, intervencija na motoru reduktora ili ventilatora itd.) obavezno isključitiglavno napajanje i to tako što se glavni grebenasti prekidač postavite na 0 i stavite u položaj zaključano. Na ovaj način izbegavaju se mogući strujni udari i ugrožavanje ljudskih života tehničkih lica koja izvodeintervenciju.



Kotao na čvrsto gorivo i prinudnom promajom treba instalirati prema važećim normama i zakonskim propisima. Svaka izmena ili na mehaničkoj konstrukciji ili na električnoj instalaciji smatraće se narušavanjem garancijiskih uslova i dovešće do njenog narušavanja.

Prilikom unošenja kotla u kotlarnicu veoma često se dešava da kompletan kotao ne može da prođe kroz postojeća vrata ili mu smeta neki drugi objekat u kotlarnici. Veoma je lako u takvim situacijama rastaviti kotao na tri osnovna sklopa:

- vodeni izmenjivač sa ložištem;
- mehanizam za transport peleta;
- silos.

Takođe, ako je položaj silosa naručen sa pogrešne strane, vrlo je lako demontiranjem i ponovnim montiranjem navedena tri sklopa dobiti željeni raspored kotla.

Osnovni zahtevi koje treba ispoštovati prilikom montiranja su:

- Prilikom postavljanja kotla treba voditi računa o njegovoj bočnoj i udaljenosti zadnje strane od mogućih prepreka. Na taj način ostavlja se mogućnost prilaza radi čišćenja pepela iz kotla ili eventualnog demontiranja sklopa mehanizma za transport peleta.
- Kotao može da bude priključen na otvoreni sistem centralnog grejanja, ali i na zatvoreni sistem centralnog grejanja. U slučaju priključenja na zatvoreni sistem, preporučuje se ugradnja ventila za termičko osiguranje oticanjem, što je određeno i odgovarajućim zakonima svake države u kojoj se kotao priključuje. Za montažu ovih ventila na samom kotlu postoje odgovarajući priključci.
- Ako u kotlarnici gde se kotao instalira dolazi do čestih prekida el. energije koristiti dodatne mere bezbednosti i zaštite rada kotla. Ako postoje delovi instalacije koji su „potopljeni” tj. na nižem su nivou od kotla i nekih grejnih tela, onda se preporučuje otvoreni sistem grejanja. Kotao mora da se nalazi na sigurnoj udaljenosti od lako zapaljivih materijala.
- Električno napajanje kotla je 3x380V (izuzev za TKAN80 Integra gde su svi potrošači monofazni) i 50Hz i priključenje svih uređaja koje kotao sadrži treba uraditi prema vazećim propisima i priključenje radi lice sa odgovarajućim ovlašćenjem.
- Priključenje na dimnjak takođe se radi prema obavezujućim propisima kao i preporukama proizvođača što se može videti u narednom tekstu.

3.2. Kotlarnica

Kotlarnica mora biti obezbeđena od smrzavanja.

Podloga za kotao u kotlarnici mora biti od nezapaljivog materijala. Preporučene vrednosti udaljenosti sve četiri strane kotla u odnosu na zidove kotlarnice ili neka druga kruta tela (akumulacioni bojler itd.) prikazane su na slici 3. Ove vrednosti udaljenosti omogućavaju siguran pristup prilikom loženja, dovoljan prostor za čišćenje i nesmetan pristup ventilatoru, mehanizmu za transport peleta, el. grejaču za potpalu i ventilu za punjenje i pražnjenje. Treba ostaviti prostor za manipulacijom kutijom za pepeo.

Sa strane silosa kotao treba udaljiti od zida od 400mm do 900mm (mereno od silosa) u zavisnosti od snage kotla. Te mere su u daljem tekstu date tablično za svaku snagu. Ovaj prostor je potreban u slučaju bilo kakvih većih intervencija na mehanizmu za transport peleta, odnosno

u situaciji kada ga treba demontirati od kotla. Prostor sa zadnje strane kotla (TKAN 80 i TKAN 100 Integra) treba da omogući lak pristup dimnjači i otvorima za čišćenje pepela na njoj. Kod ostalih kotlova ove serije prostor sa zadnje strane treba da omogući manipulaciju sa multiciklonom. Sa prednje strane kotla potrebno je omogućiti lako otvaranje svih vrata i prostor za elemente otprašivanja.

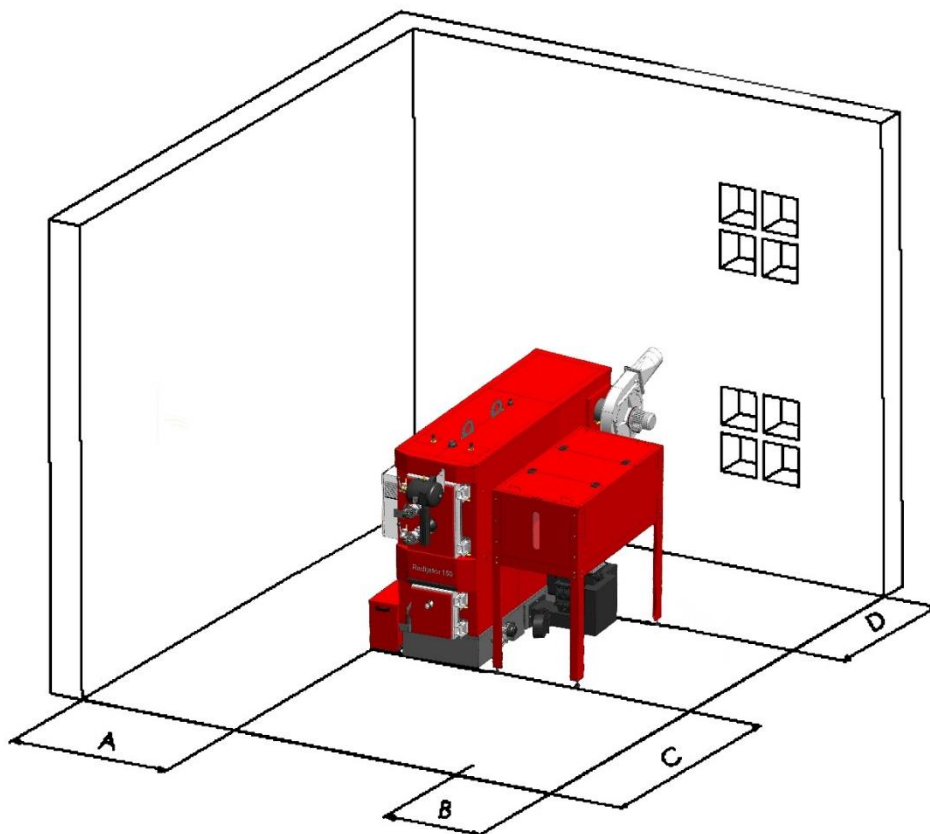

Slika3. Pozicioniranje kotla u kotlarnici

Tip kotla	DIMENZIJE			
	A* (mm)	B (mm)	C (mm)	D (mm)
TKAN 80 Integra	500	400	1000	800
TKAN 100 Integra	500	400	1000	800
TKAN 150 Integra	500	550	1000	1000
TKAN 200 Integra	600	650	1000	1000
TKAN 250 Integra	600	900	1000	1100
TKAN 300 Integra	600	900	1000	1100

Tabela 2. Pozicioniranje kotla u odnosu na zidove kotlarnice

NAPOMENA: Svi kotlovi imaju jednu spiralu za poluautomatsko čišćenje prostora oko ložišta. Automatski sistem za otprašivanje. TKAN 80 Integra i TKAN 100 Integra imaju dimnjaču sa ventilatorom dok kotlovi većih snaga fabrički je ugrađen multiciklon.

Kotlarnica mora da ima potrebnu ventilaciju, odnosno dovoljno velike otvore za ulaz svežeg i izbacivanje potrošenog vazduha.

Ukupna površina ovih otvora je minimalno 200cm² za snage do 80kW, a za snagu preko 80kW površina mora biti veća za još 2cm² po kilovatu.

$$A=200\text{cm}^2+\frac{2\text{cm}^2}{\text{kW}}\times(\sum Q_n-80\text{kW}) \quad \sum Q_n = \text{moguće snage preko 80kW.}$$

Nedostatak dovoljne ventilacije u kotlarnici može da uzrokuje više problema u radu kotla. Glavni problem je nemogućnost postizanja visokih temperature izlazne vode tj. ne postizanje maksimalne snage što dovodi do kondezovanja u kotlu.

- Uzeti u obzir neophodan minimalni prostor koji je potreban za prilaz sigurnosnim elementima i za izvršenje operacija čišćenja i servisa elektro i mehaničkih komponenti.
- Utvrditi da li je stepen električne zaštite u skladu sa karakteristikama prostorije u kojoj ce kotao biti smešten.
- Zabranjeno je izlaganje kotla atmosferskim neprilikama. Sam kotao nije predviđen za spoljnu montažu i ne sadrži sistem protiv smrzavanja.
- Zabranjeno je zatvaranje ventilacionih otvora na prostoriji u kojoj se nalazi kotao. Ventilacioni otvori su neophodni za pravilno sagorevanje.

3.3. Priključenje na dimnjak

Najoptimalnije postavljanje kotla na dimnjaču je takvo da prava koja spaja centar izlaza dimnih gasova iz kotla i centar priključenja na dimnjak bude u blagom usponu (do 3%) (pogledati **Slika 4**).

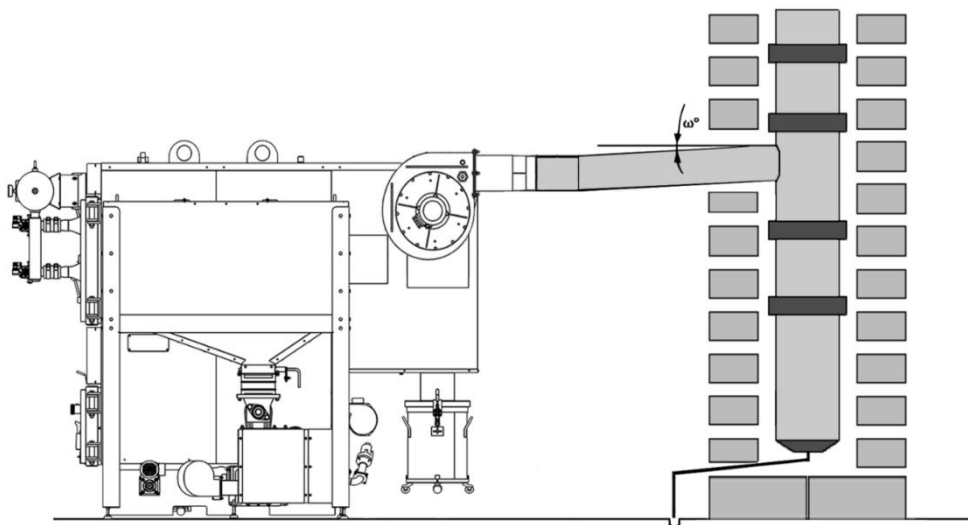

Slika 4. Prikaz priključenja na dimnjak

Treba izbegavati ako je moguće lukove, a ako nije onda je maksimalni broj lukova (2). Dimni kanal od kotla do dimnjaka poželjno je izolovati, posebno ako ima lukova i dužih deonica. Na dimnoj cevi, približno 100mm od dimnjače kotla, treba izbušiti otvor i montirati uložak za temperaturnu sondu dimnih gasova. Bez informacije o temperaturi dimnih gasova nema ni automatskog režima rada kotla.

Sam dimnjak treba da je napravljen od keramičkih cevi, oko njih treba da je izolacija debljine 3-5cm i zadnji spoljni sloj je cigla ili specijalni dimnjački elementi. Ako dimnjak ipak nije od keramike već od cigle, površina svetlog preseka takvog dimnjaka mora da bude 30% veća nego ovakva površina keramičkog dimnjaka.

Dimnjak mora da ima i vratanca za čišćenje, a ona moraju dobro da dihtuju. Izlaz dimnjaka na krovu mora da bude po određenim propisima. Razlikuju se dva slučaja: ako je ugao krova manji od 120° i ako je ugao krova veći od 120° . Za ugao manji od 120° visine dimnjaka iznad krova je 1m, a za ugao veći od 120° treba pogledati skicu.

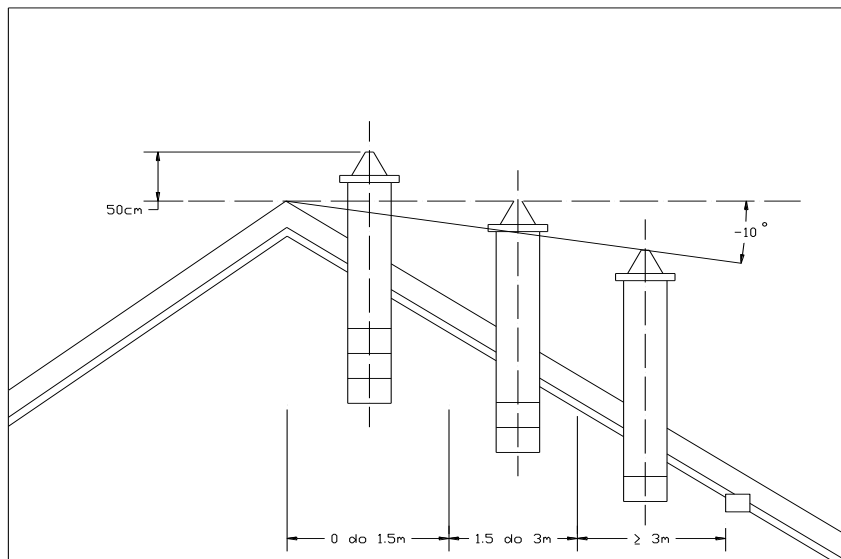

Slika 5. Prikaz dimnjaka

Ukoliko mislite da je dimnjak prejak i da isuviše hladnog vazduha prolazi kroz kotao, na izlazu iz kotla postoji klapna kojom može da se smanji protok izduvnih gasova. Dimnjak treba redovno da se čisti ili barem jedanput godišnje.



Ukoliko dimnjak nije propisne visine, poprečnog preseka ili ako se ne čisti moguće su komplikacije u radu kotla. Pre svega nije moguć visokotemperaturni režim rada, tj. nema maksimalne radne snage, a posledice toga je pojava kondenzacije što utiče na radni vek kotla.



Slab dimnjak je glavni razlog da u toku potpale kotla ili u toku rada imamo pojavu dima na gornjim ili donjim vratima, naročito pri većim brojevima obrtaja ventilator.

3.4. Otprašivanje

Otprašivanje kotla podrazumeva automatsko čišćenje kotla od čađi upotrebom komprimovanog vazduha. Da bi čišćenje kotla od čađi bilo efikasno, potrebno je celu instalaciju uraditi po standardima koji regulišu ovu oblast. Potrebno je izabrati odgovarajući kompresor, obezbediti kvalitetan vazduh i odgovarajuću količinu vazduha za rad ventila koji upuštaju vazduh pod pritiskom u kotao.

Ceo sistem se sastoji iz tri jedinice što se vidi na **Slici 6**:

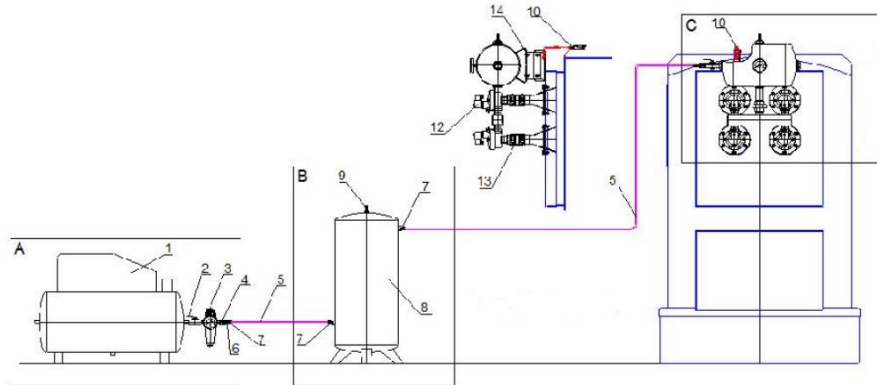

Slika 6. Šematski prikaz sistema za otprašivanja

- **Jedinica A** - kompresorska jedinica
- **Jedinica B** – rezervoar vazduha*
- **Jedinica C**- otprašivačka jedinica

Jedinica A:

Obezbeđuje je kupac.



Da bi se priznala garancija, koju daje proizvođač, potrebno je nabaviti kompresorsku jedinicu koja ispunjava sledeće uslove:

- Kompresor mora imati minimalni protok vazduha od 200 L/min
- Maksimalni pritisak 9 do 10bar
- Rezervoar na kompresoru od minimum 200 L
- Pripremnu grupu za vazduh koja ispunjava ISO standard ISO 8573.1 klase 14.1 (odvajanje čvrstih čestica, vlage i ulja)
- Manometar



1. Obavezno, jednom dnevno, ispuštati vodu iz rezervoara kompresora pomoću ventila koje se nalazi na dnu rezervoara.



2. Obavezno prazniti čašu u pripreмноj grupi u kojoj se sakuplja kondez (voda). Ukoliko kompresor nema rezervoar zapremine 200 L.

Jedinica B:

Obezbeđuje je kupac.

*Obezbediti rezervoar zapremine min 200 L. Radi kontinualnog snabdevanja vazduha jedinice C.

***Ovo samo u slučaju da kompresor nema sopstveni rezervoar zapremine min. 200 L.

Ovaj rezervoar mora biti atestiran na radni pritisak 10bar, probni pritisak min. 13bar i mora imati ventil sigurnosti na sebi naštelovan na 10bar. Može biti horizontalni ili vertikalni.



Rezervoar za vazduh i ventil sigurnosti moraju biti atestirani. Korisnik opreme pod pritiskom dužan je da vrši kontrolu rezervoara i ventila sigurnosti, koji je regulisana pravilnikom o pregledima i ispitivanju opreme pod pritiskom.



Obavezno, jednom dnevno, ispuštati vodu iz rezervoara pomoću ventila koji se nalazi na dnu rezervoara.

Jedinica C:

je sastavni deo kotla i sastoji se od:

- rezervoara za vazduh,
- nosač rezervoara,
- ventil sigurnosti,
- rasteretni ventil 1/2",
- manometar 1/4",
- brzorastavljiva spojka 1/2" SN,
- priključak za brzu spojku 1/4" UN,
- priključak za crevo 10/8 1/4" SN,
- nosač pulsnih ventila,
- pulsnih ventila 6/4",
- spojnih elemenata (šelne, gumena creva i priključci),
- mikroprekidač.



Rezervoar za vazduh i ventil sigurnosti moraju biti atestirani. Korisnik opreme pod pritiskom je dužan da vrši kontrolu, rezervoara i ventila sigurnosti, koja je regulisana pravilnikom o pregledima i ispitivanju opreme pod pritiskom.

Sve elemente jedinice C obezbeđuje proizvođač:

Za TKAN 80 Integra i TKAN 100 Integra ne preporučuje se ugradnja ventila za otprašivanje i nisu fabrički integrisani.

Za TKAN 150 Integra isporučuje se rezervoar od 10 L i pulsni ventil – 2 kom.

Za TKAN 200 Integra, TKAN 250 Integra i TKAN 300 Integra isporučuje se rezervoar od 24 L i pulsni ventil – 4 kom.

Princip rada:

Princip rada jedinice C je zasnovan na brzom ubacivanju komprimovanog vazduha kroz otvore na vratima da bi se dimovodne cevi kvalitetno očistile od čađi. Automatsko uključivanje pulsnih ventila je fabrički podešeno i uključuje se jedan po jedan u određenim vremenskim intervalima. Ugrađen je i mikroprekidač na gornjim vratima koji će u slučaju otvaranja gornjih vrata momentalno prekinuti funkciju otprašivanja. Posle zatvaranja gornjih vrata, aktivira se mikroprekidač i uključuje se automatsko otprašivanje.

3.5. Montaža multiciklona



Modeli TKAN 80 Integra i TKAN 100 Integra nemaju fabrički integrisan ciklon već ventilator na dimnjači.

Da bi se umanjilo ispuštanje čestica prašine iz dimnih gasova preporučuje se ugradnja multiciklona i centrifugalnog ventilatora. Njegovom ugradnjom ujedno se može smanjiti potrebna visina dimnjaka. Uz multiciklon i ventilator potrebno je ugraditi i regulaciju kotla. Multiciklon je skup više ciklona malog prečnika koji se postavljaju u zajedničko kućište.

Dimni gasovi se uvode tangencijalno pri vrhu cilindričnog dela ciklona, pri čemu usled delovanja centrifugalne sile nastaje odvajanje čestica iz gasa, koje dospeju do zida ciklona. Delovanjem sile težine odvojene čestice se spiralno spuštaju niz kupasti deo ciklona u kontejneru. Očišćena struja gasa spiralno ističe kroz uronjenu cev ciklona u atmosferu ili sistem cevovoda.

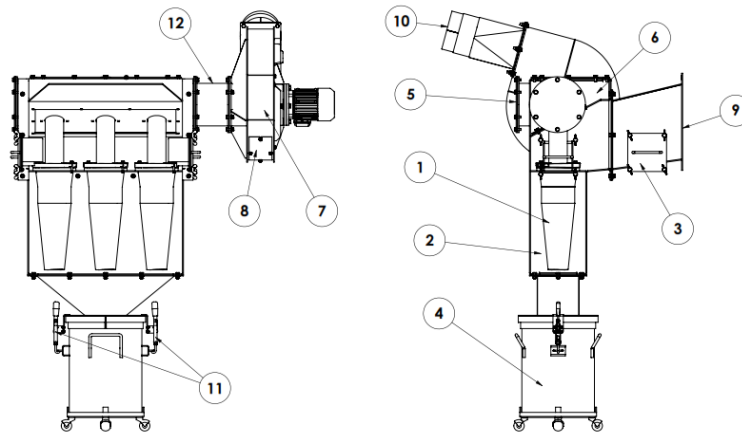

Slika 7. Principijalna šema multiciklona

- 1 Ciklon
- 2 Telo multiciklona
- 3 Otvor za čišćenje
- 4 Kontejner
- 5 Alternativni nosač ventilatora
- 6 Kućište multiciklona
- 7 Centrifugalni ventilator
- 8 Otvor za čišćenje
- 9 Ulaz dimnih gasova
- 10 Izlaz prečišćenih gasova
- 11 Mehanizam za otvaranje
- 12 Nosač centrifugalnog ventilatora

Na **Slici 7.** se vide glavni delovi multiciklona, a to su: kućište, telo i kontejner.

Kućište je ispunjeno sa određenim brojem ciklona malog prečnika i to je ujedno i najvažniji deo multiciklona. Opremljen je sa tri priključka na koje se može postaviti centrifugalni ventilator. Dva se nalaze na bočnim stranama, a jedan je na zadnjoj strani kućišta. Takođe se na bočnim stranama nalaze i otvori za čišćenje ciklona.

Telo multiciklona usmerava krupnije čestice u kontejner.

Kontejner služi za prikupljanje krupnijih čestica koje su izdvojene iz dimnih gasova. Snabdeven je mehanizmom za otvaranje, koji služi da se kontejner odvoji od tela da bi se sadržina kontejnera ispraznila.



Čišćenje multiciklona treba obaviti jednom mesečno. Na bočnim stranama kućišta postoje dva otvora za kućište. Skinuti poklopac i detaljno očistiti unutrašnjost kućišta. Voditi računa prilikom vraćanja poklopca da se traka za dihtovanje ne pomeri. Takođe treba očistiti i centrifugalni ventilator koji na sebi ima otvor za čišćenje.

Centrifugalnim ventilatorom upravlja frekventi regulator. Frekventi regulator je vođen automatikom kotla.

Usled dejstva čestica iz dimnih gasova, na radnom kolu ventilatora nakupi se sloj čađi, što se može primeniti sa promenom zvuka ventilatora. ODMAH je potrebno izvršiti čišćenje i ponovno balansiranje radnog kola, jer dalja upotreba može dovesti do mehaničkih oštećenja ležajeva motora, radnog kola kao i samog kućišta ventilatora.

4. Presek TKAN Integra kotla sa opisom elemenata

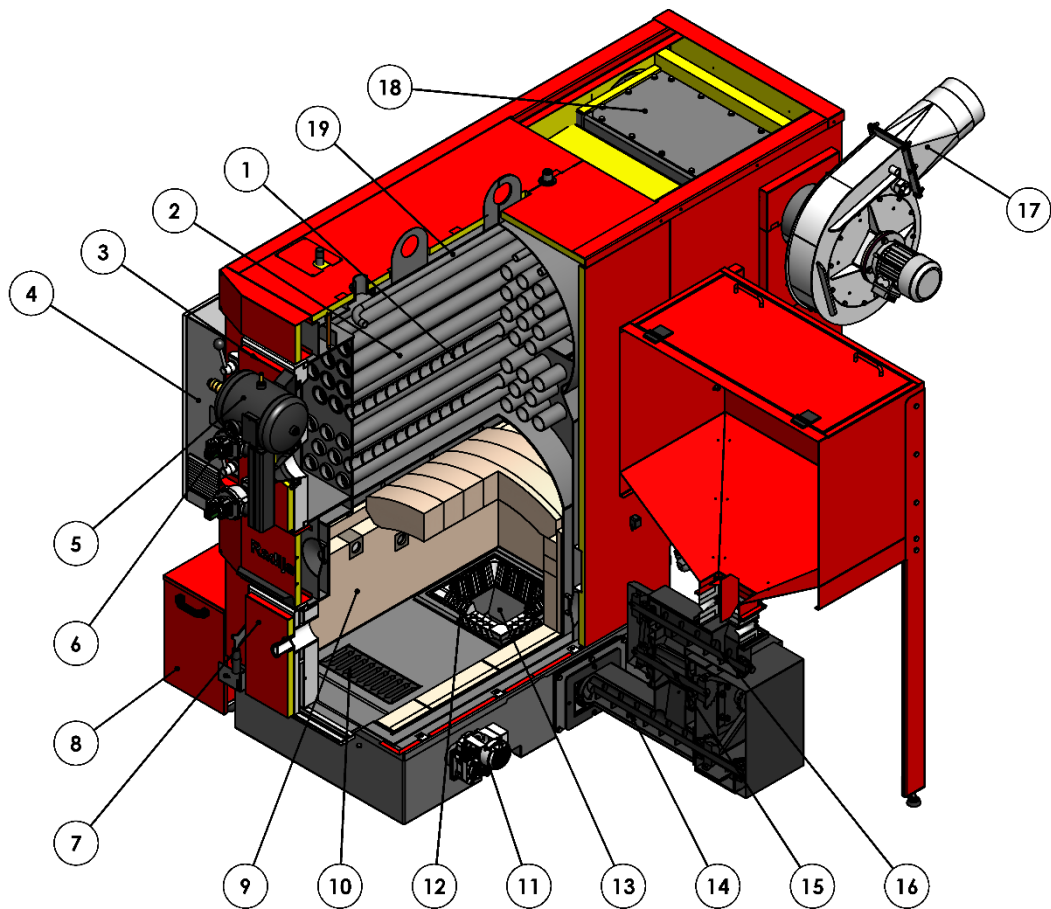

Slika 8. Presek TKAN Integra kotla

1. Turbulatori
2. Cevni izmenjivač
3. Vrata za čišćenje cevnog izmenjivača i samog kotla
4. Razvodni ormar sa automatikom
5. Boca komprimovanog vazduha
6. Impulsni elektroventil
7. Vrata za loženje i potpalu
8. Kanta za pepeo
9. Ozida ložišta
10. Spirala za automatsko izbacivanje pepela iz prostora ložišta
11. Motor za pokretanje spirale za automatsko čišćenje ložišta
12. Liveni segmenti
13. Ložište kotla
14. Donja osovina pužnog transportera
15. Čelijasti dozator (valvola)
16. Gornja osovina pužnog transportera
17. Centrifugalni ventilator multiciklona
18. Multiciklon
19. Izmenjivač termičkog osiguranja

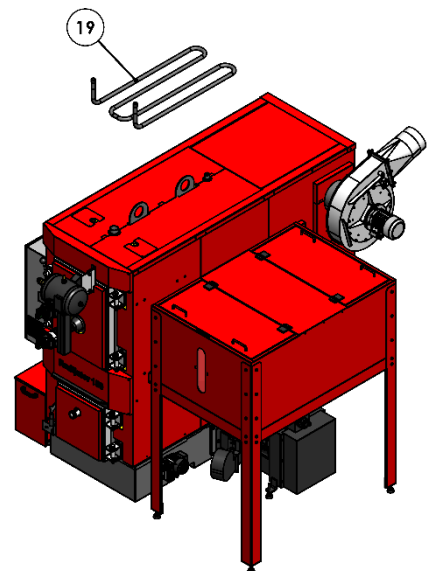

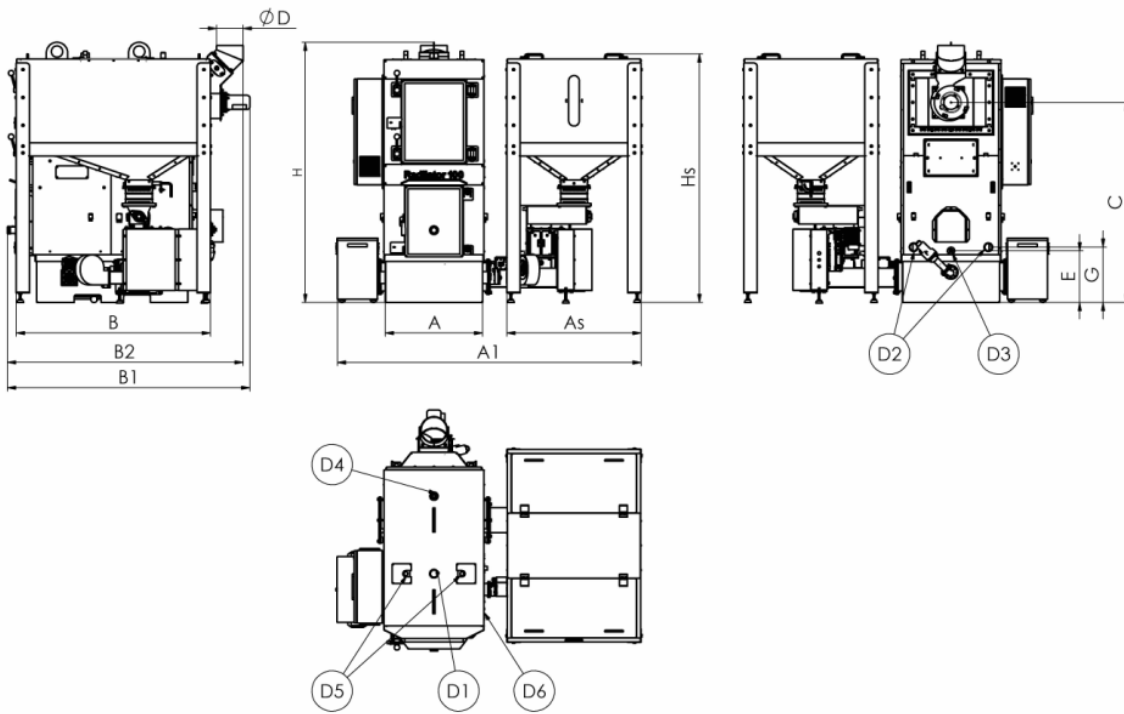

Slika 9. Crtež sa dimenzijama i priključcima za TKAN 80 Integra i TKAN 100 Integra

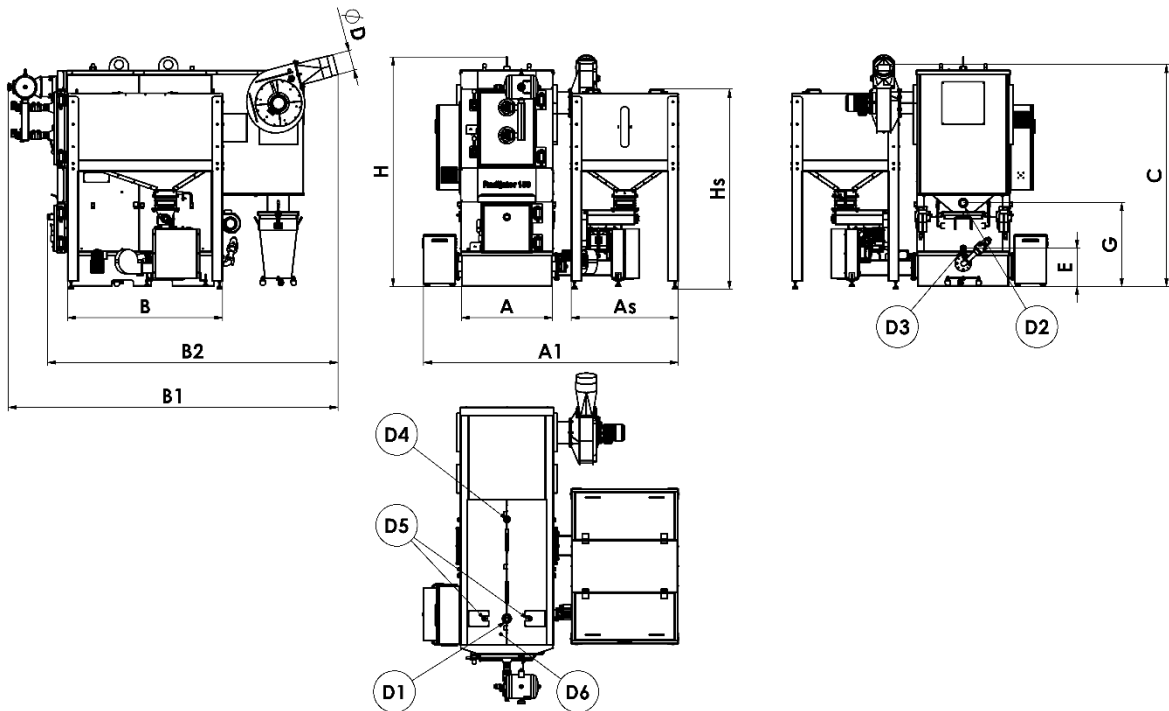

Slika 10. Crtež sa dimenzijama i priključcima za TKAN 150 Integra

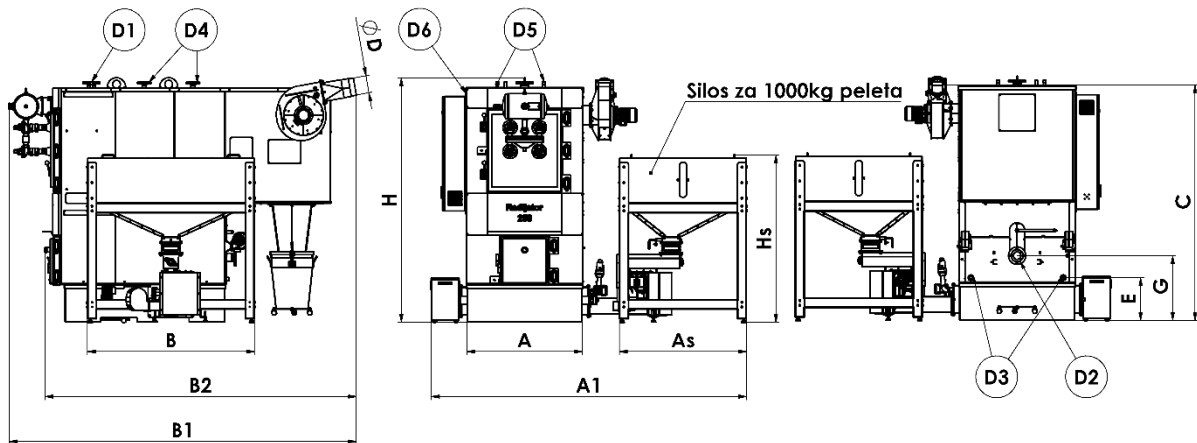

Slika 11. Crtež sa dimenzijama i priključcima za TKAN 200 Integra, TKAN 250 Integra i TKAN 300 Integra

Priključci/Connection:

- D1-Priključak za toplu vodu/Connection for hot water from boiler
- D2-Priključak za hladnu vodu/Connection for cold water of boiler
- D3-Priključak za punjenje i pražnjenje/Connection for filling and emptying boiler
- D4-Priključak za sigurnosnu grupu/Connection for safety group
- D5-Priključak za ventil termičkog oticanja/Connection for thermal valve insurance swelling
- D6-Priključak za sondu ventila termičkog osiguranja/Connection for probe of thermal valve insurance swelling

Na crtežu sa dimenzijama za TKAN 200 Integra, TKAN 250 Integra i TKAN 300 Integra, prikazan je silos koji može da primi 1000kg peleta, u tabeli sa dimenzijama date su vrednosti za isti. U slučaju da se kupac odluči za neku drugu varijantu silosa potrebno je kontaktirati Radijator Inženjering kako bi se dobile informacije vezane za gabarite tog silosa.

5. Tabela sa dimenzijama

Tip kotla (Integra)		TKAN 80 Integra	TKAN 100 Integra	TKAN 150 Integra	TKAN 200 Integra	TKAN 250 Integra	TKAN 300 Integra		
Snaga	kW	80	100	150	200	250	300		
Radni pritisak	kPa	300	300	300	300	300	300		
Probni pritisak	kPa	450	450	450	450	450	450		
Zapremina vode u kotlu	L-cca	368	460	690	920	1150	1380		
Masa kotla	kg	1191	1415	2288	3240	4140	4440		
Masa silosa	kg	100	165	165	225	225	225		
DIMENZIJE	A	mm	730	730	850	1005	1260	1260	
	A1		1788	2276	2394	2942	3455	3455	
	As		606	1006	1006	1394	1394	1394	
	B		1020	1456	1456	1830	1830	1830	
	B1		1655	1817	3099	3386	3809	3809	
	B2		1595	1767	2729	2988	3414	3414	
	C		1507	1507	2080	2515	2567	2567	
	ØD		180	200	190	190	190	190	
	E		390	390	359	465	467	467	
	G		417	417	784	675	707	707	
	H		1960	1960	2151	2547	2663	2663	
	Hs		1736	1872	1872	1822	1822	1822	
	D1		col	2"	2"	2"	DN80 NP6	DN80 NP6	DN80 NP6
	D2			2"	2"	2"	DN80 NP6	DN80 NP6	DN80 NP6
	D3			1/2"	1/2"	1/2"	DN40 NP16	DN40 NP16	DN40 NP16
	D4			3/4"	3/4"	3/4"	DN40 NP16	DN40 NP16	DN40 NP16
	D5			1/2"	1/2"	1/2"	1"	1"	1"
D6	1/2"	1/2"		1/2"	1/2"	1/2"	1/2"		
Maseni protok (kg/h)		313		468	878	1116	1353	1461	

Tabela 3. Dimenzije kotlova

6. Hidraulična šema

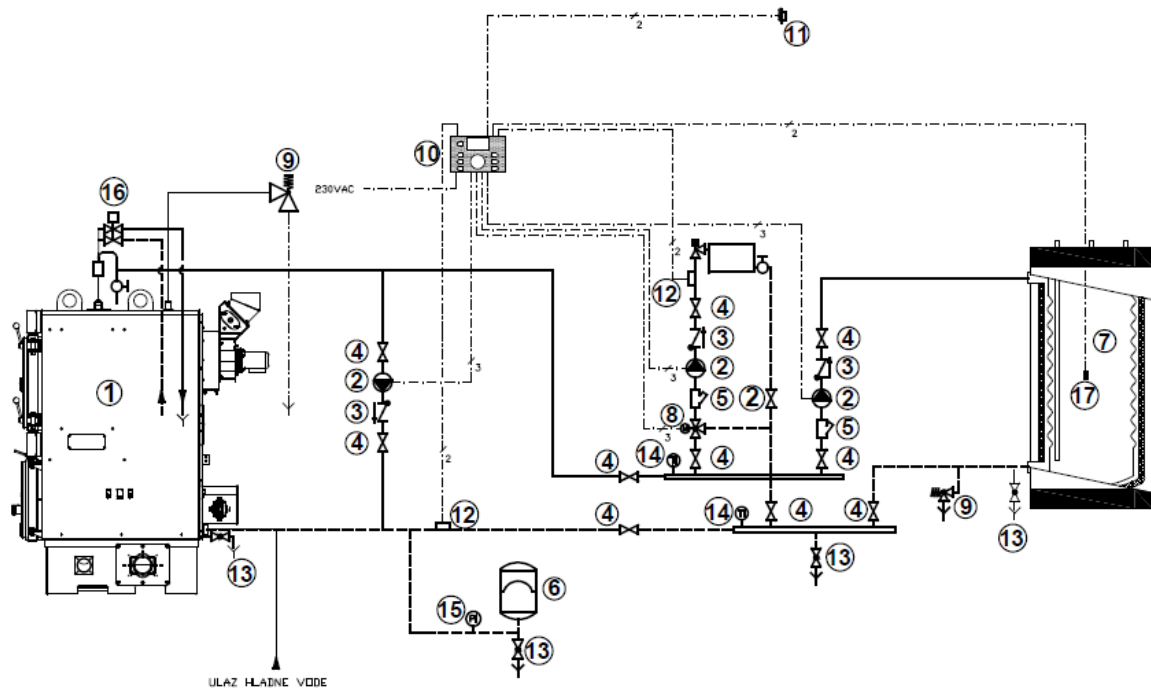

Slika 12. Hidraulična šema TKAN 80 Integra

1. Toplovodni kotao na pelet
2. Cirkulaciona pumpa
3. Nepovratni ventil
4. Zaporna slavina
5. Hvatač nečistoća
6. Zatvorena ekspanziona posuda
7. Bojler sanitarne tople vode
8. Trokraki mešni ventil
9. Ventil sigurnosti
10. Upravljačka jedinica-regulator
11. Spoljni senzor temperature
12. Cevni senzor temperature
13. Slavina za punjenje i pražnjenje
14. Termometar
15. Manometar
16. Ventil za termičko osiguranje
17. Senzor akumulatora tople vode

7. Objašnjenje rada automatike TKAN



Prvo puštanje kotla u rad obavlja tehničko lice koje ima sertifikat izdat od strane Radijator Inženjeringa. Obavezna je obuka korisnika kotla.

Na taj način to lice je ovlašćeno da prijavi servisnoj službi u samoj fabrici vreme kada je kotao počeo da radi i u kakvom je stanju kotao bio prilikom prvog paljenja, dok kopiju izveštaja o puštanju kotla u rad zadržava. Garancija i upustvo za upotrebu se daje kupcu. Jedan primerak garancije se šalje proizvođaču.

Ako garancija nije ispunjena, ona nije važeća.

Samo kotlovi koji su pušteni u rad od strane ovlašćenog tehničkog lica podležu uslovima kompletne garancije od dve godine.

Naredni tekst je namenjen samom korisniku kotla, kao jedna vrsta podsetnika, da ako ugasi kotao (npr. zbog čišćenja) bude u stanju da samostalno pokrene kotao.



Parametri vezani za rad kotla a koji su dostupni korisniku su na samom displeju. Ostale parametre koji su u tzv. skrivenom meniju ne treba menjati bez saglasnosti tehničkog lica koje je pustilo kotao u rad ili proizvođača.

7.1. Displej automatike

Na narednim slikama prikazan je sistem funkcionisanja ekrana osetljivog na dodir kao i kako se možete kretati kroz strukturu ekrana i vršiti podešavanja.

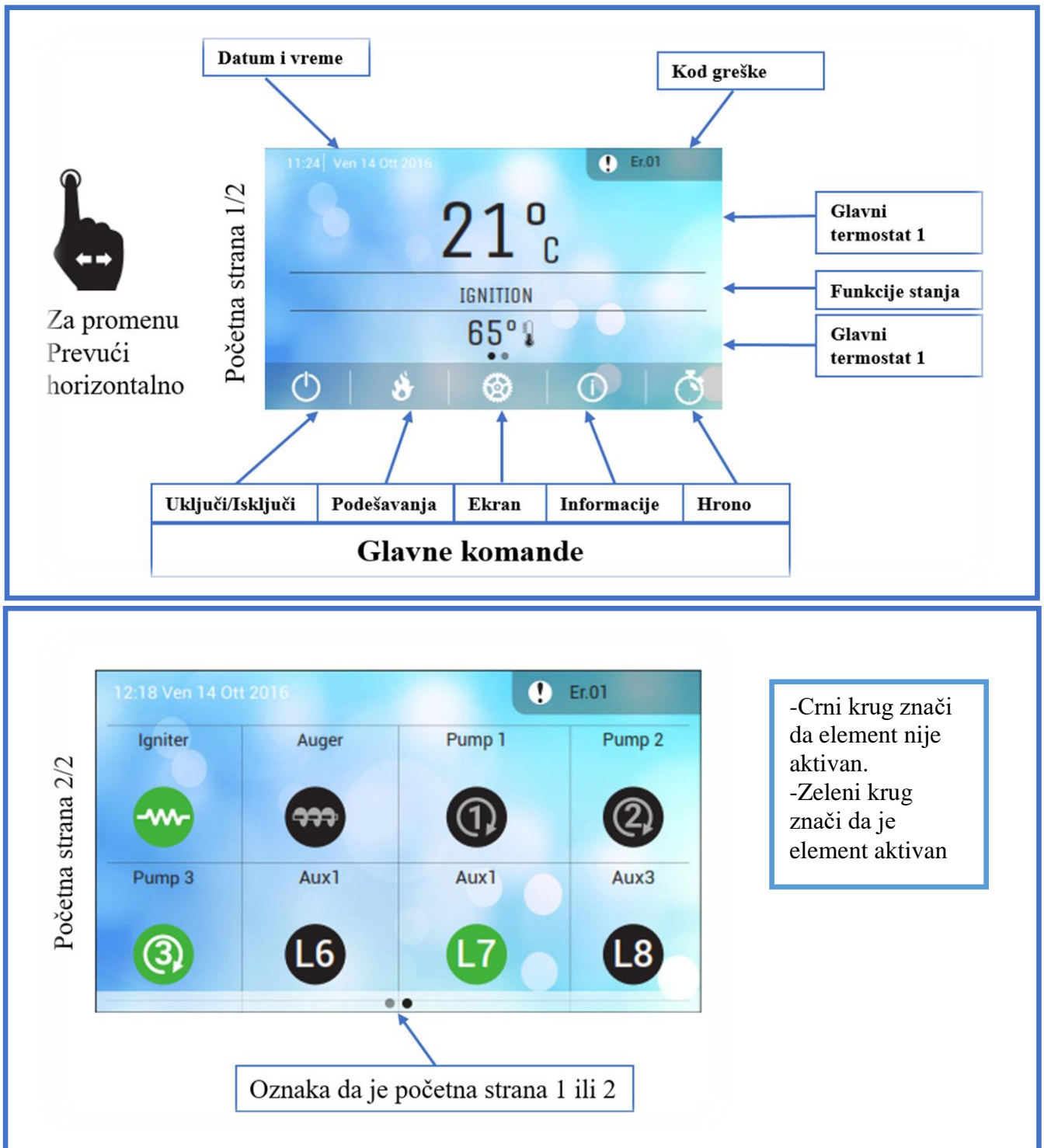

Slika 13. Prikaz početnih stranica 1 i 2

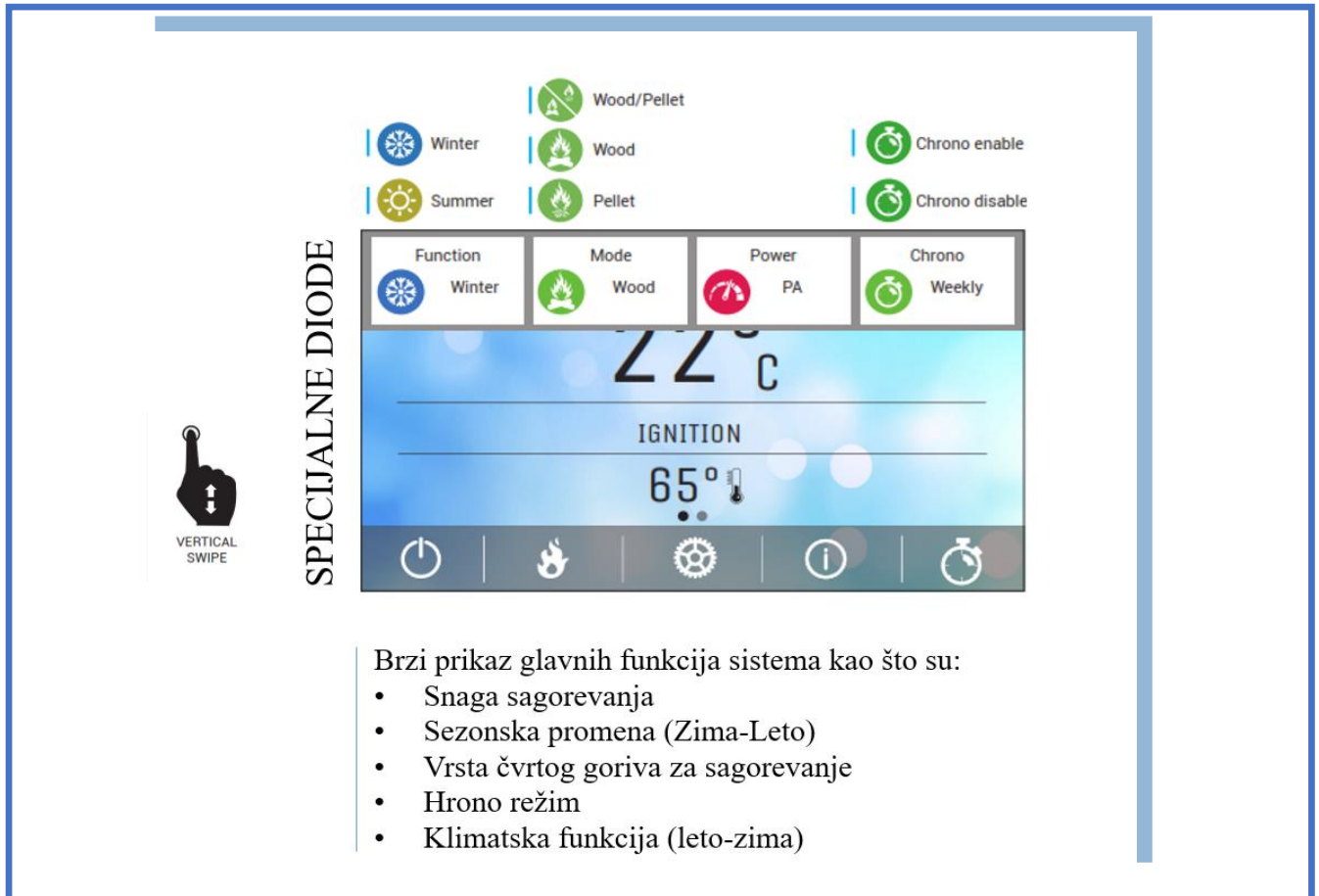

Slika 14. Brzi pristup nekim funkcijama sistema



Slika 15. Rad sistema bez greške

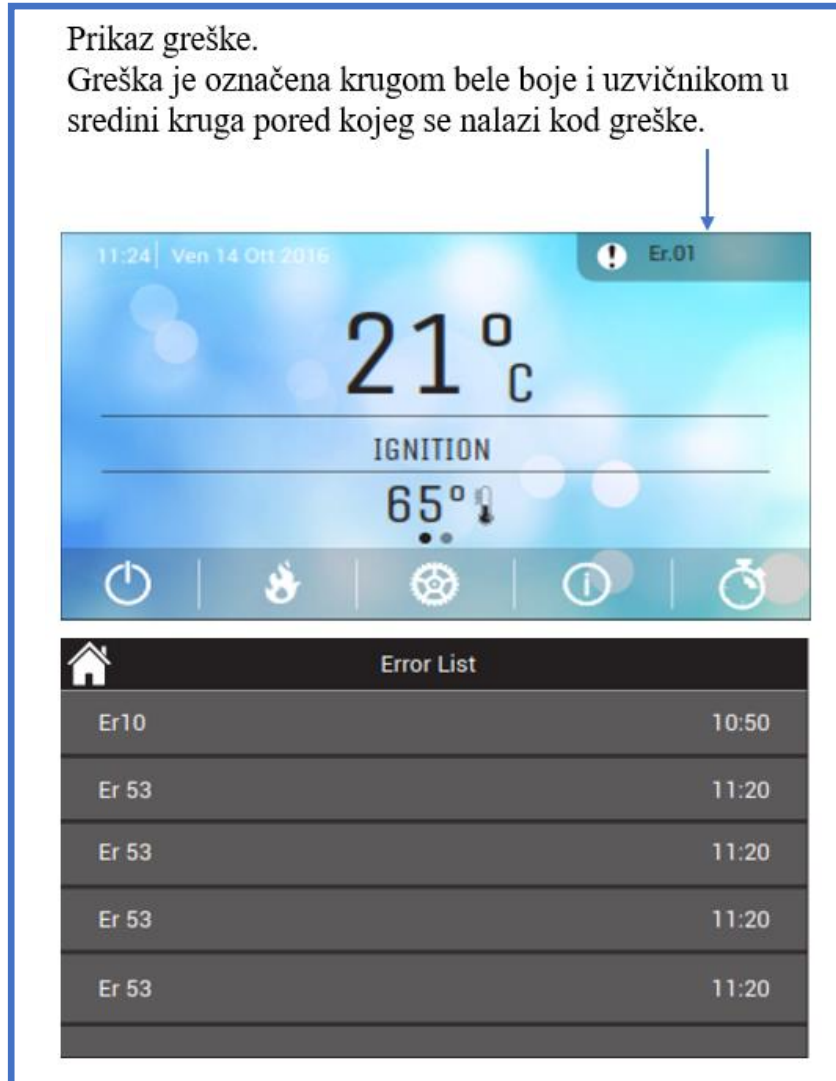

Slika 16. Prikaz sistema sa greškom i lista grešaka



Slika 17. Prikaz glavnog dispelja i podmenija

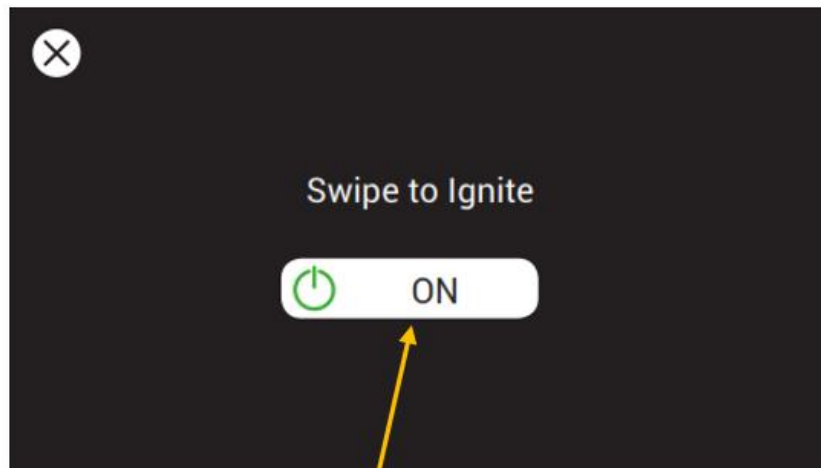

Ekran koji služi za:

- Uključiti sistem: ON
- Isključiti sistem: OFF
- Reset alarma

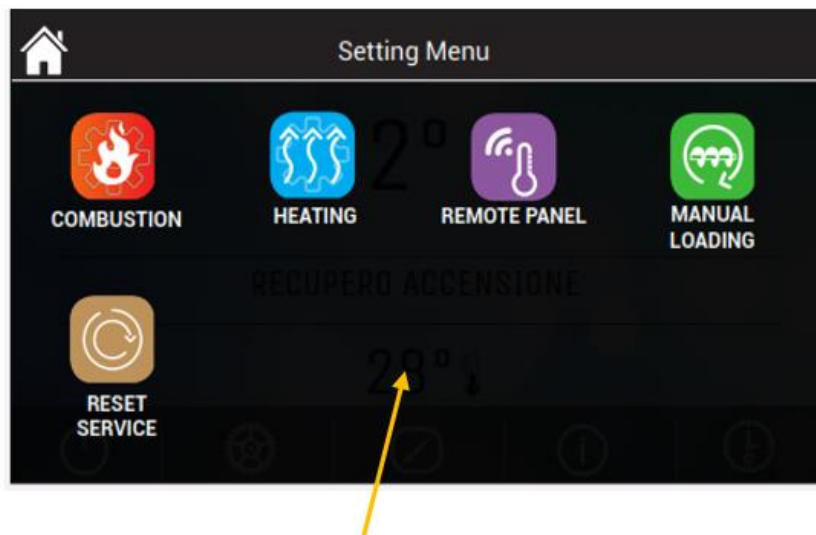

Na ovom ekranu možete videti sve varijable za pravilno funkcionisanje sistema grejanja

Slika 18. Prikaz funkcija ekrana

HRONO REŽIM RADA

Za promenu hrono programa, pritisnuti HRONO ikonicu na Početnom ekranu

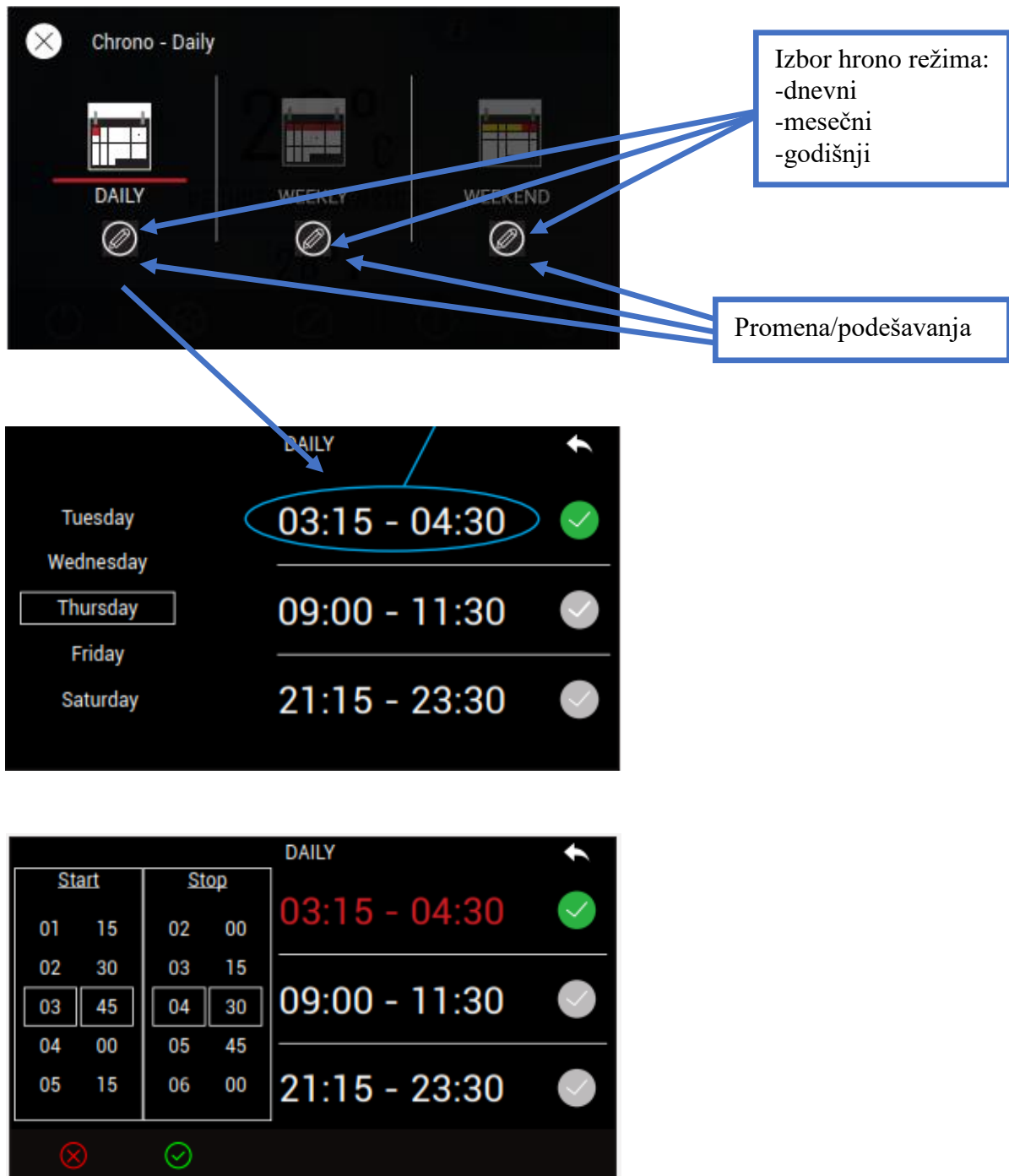

The image shows three screenshots of the Chrono control interface. The first screenshot shows the 'Chrono - Daily' screen with three mode options: DAILY, WEEKLY, and WEEKEND. Each option has a corresponding icon below it. Blue arrows point from a text box 'Izbor hrono režima: -dnevni -mesečni -godišnji' to these icons. Another set of blue arrows points from a text box 'Promena/podešavanja' to the same icons. The second screenshot shows the 'DAILY' mode selected, displaying a schedule for Tuesday, Wednesday, Thursday, Friday, and Saturday. The time range for Tuesday, '03:15 - 04:30', is circled in blue. The third screenshot shows the 'DAILY' mode with a detailed time selection grid. The grid has columns for 'Start' and 'Stop' times, with sub-columns for minutes. The selected time range '03:15 - 04:30' is highlighted in red. A red 'X' icon is at the bottom left, and a green checkmark icon is at the bottom right.

Izbor hrono režima:
-dnevni
-mesečni
-godišnji

Promena/podešavanja

Start	Stop	Time Range	Status
01 15	02 00	03:15 - 04:30	✓
02 30	03 15	09:00 - 11:30	✓
03 45	04 30	21:15 - 23:30	✓
04 00	05 45		
05 15	06 00		

Slika 19. Hrono režim rada



Slika 20. Meni za podešavanje displeja

DISPLAY MENI - PODEŠAVANJE DISPLEJA



Meni koji služi za odabir **jezika**



Jačina osvetljenja



Minimalno osvetljenje: funkcija Vam omogućava da izaberete minimalni nivo osvetljenosti koji će uređaj automatski podesiti nakon 30s neaktivnosti



Standby display (stanje pripravnosti): ako je omogućena, ova funkcija će postaviti ekran u stanje pripravnosti nakon 1min neaktivnosti



„Adresa kontrolnog panela“: zaštićena je passwordom i koristi se za napredna podešavanja



Reset kontrolnog panela: funkcija koja omogućava da kontrolni panel bude resetovan



Zvuk: ova funkcija omogućava korisniku da uključi/onemogući zvuke emitovane sa kontrolne table



Meni za brisanje grešaka sistema: ova funkcija je zaaštićena lozinkom (isto kao u tehničkom meniju) omogućava korisniku da obriše listu grešaka koje je zabeležila kontrolna table. Memorija je 64 zapisa.

Nodes list/Lista čvorova: meni dozvoljava da se vide svi uređaji koji su povezani Modbus-om, sa informacijama o firmware i revizijama

Wallpaper/Pozadina: meni za izbor pozadine. Osam pozadina je raspoloživo.

Control panel info: verzija softvera i revizije.

Error poruke i prikaz bitnih veličina

- Er01 – Aktivirao se sigurnosni termostat 1 (može da se pojavi i kada je kotao isključen)
- Er02- Aktivira se sigurnosni termostat 2 (može da se pojavi i kada je kotao isključen)
- Er03 – Gašenje zbog niske temperature dimnih gasova
- Er04 - Gašenje zbog pregrevanja vode
- Er05 – Gašenje zbog ekstremno visokih temperatura dimnih gasova
- Er06 – Signal senzora temperature peleta je u prekidu
- Er07 – Greška enkodera. Nema signal sa enkodera.
- Er08 – Enkoder signalizira pogrešnu brzinu obrtanja.
- Er09 – Nizak pritisak vode.
- Er10 – Visok pritisak vode.
- Er11 – Greška koja signalizira problem sa satom realnog vremena u automatici
- Er12 – Gašenje zbog neuspele potpale
- Er14 – Senzor pritiska je očitao van graničnu vrednost (pojavljuje se samo kada je bar jedan od ventilatora uključen)
- Er15 - Gašenje zbog nestanka struje dužeg od 50min
- Er16 – RS 485 Komunikaciona greška
- Er18 – Prazan spremnik peleta
- Er20 – Grate senzor greška (zatvoren kontakt kada je sistem u Pelet modu)
- Er23 – Senzor sanitarne vode
- Er25 – Pokvaren motor za automatsko čišćenje (Breizer Cleaning Motor)
- Er25 – Pokvarena mašina za čišćenje (Cleaning Engine)
- Er34 – Pritisak je pao ispod granice za minimalnu dozvoljenu vrednost
- Er35 – Pritisak je iznad granice za maksimalnu dozvoljenu vrednost

Ostale poruke

- | | |
|------------------------|---|
| Sensor | Prikazuje status senzora temperature (jedan ili više, koliko ih je instalisano). Poruka je prikazana tokom faze provera i pokazuje da li je vrednost koju pokazuje ta sonda minimalna ili maksimalna (zavisno od tipa sonde). Proverava da li je sonda otvorena/otkačena ili kratko spojena. Kada je sonda otvorena prikazuje minimalnu temperaturu iz opsega. Kada je sonda kratko spojena pokazuje maksimalnu temperaturu iz opsega. |
| Service T66. | Poruka da je kotao radio određen broj sati, unapred definisan parametrom Pozvati servisera. |
| Cleaning | Poruka da je kotao radio određen broj sati, unapred definisan parametrom T67 . Kotao treba očistiti. |
| Block | Poruka koja se pojavljuje u fazama posle podfaze Preload (Ignition) ako kotao nije ručno ugašen |
| Door | Otvorena vrata |
| Link Error | Zaključana komunikacija između lambda ploče i tastature/ekrana. |
| Transfer Failed | Učitavanje novih parametara nije uspelo. Pokušajte ponovo. |

7.2. Start rada kotla na biomasu

- Kotao priključen na hidraulički sistem.
- Izbušiti otvor prečnika 4 mm na gornjoj strani dimne cevi u zoni koja je veoma blizu dimnog izlaza kotla. **samo za model TKAN 80 Integra i TKAN 100 Integra*
- Uveriti se da je mehanizam za transport peleta čvrsto oslonjen na pod, da je klapna ventilatora maksimalno otvorena, u slučajevima da je ventilator sa klapnom.
- Položaj vođica klapne za sigurnosni vazduh je prikazan na slici. Položaj je bitan pri nominalnom radu kotla.



*Slika 21. Položaj klapne ventilatora
 samo za model TKAN 80 Integra i TKAN 100 Integra

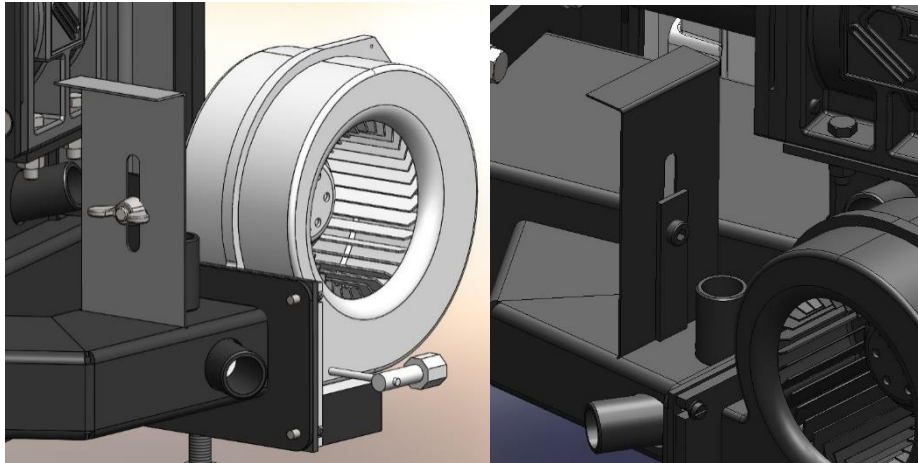

Slika 22. Položaj vođice klapne pri nominalnom radu

- TKAN Integra 80 i 100: dužina otvora 51mm
- TKAN Integra 150: dužina otvora je maksimalna
- TKAN Integra 200: dužina otvora je maksimalna
- TKAN Integra 250: dužina otvora je 45mm
- TKAN Integra 300: dužina otvora je 45mm

- Dovedi napajanje do glavnog razvodnog-ormara na kotlu. Glavni grebenasti rastavljač staviti u poziciju 1.
- Sipati pelet u silos i zatvoriti ga.

- U ovoj fazi potrebno je ubaciti pelet u komoru za sagorevanje i to radom transportnog mehanizma za pellet (pellet feeding system). Na taj način postizemo kontinualno raspoređen pelet od komore za sagorevanje pa do silosa. Do pokretanja mehanizma za pelet može doći samo u fazi rada kada na displeju piše „OFF“ (Slika 17).

Nalaganje komore peletom tzv. ručnom komandom vršiti do vrha delova od sivog liva, što je prikazano slikom 16.

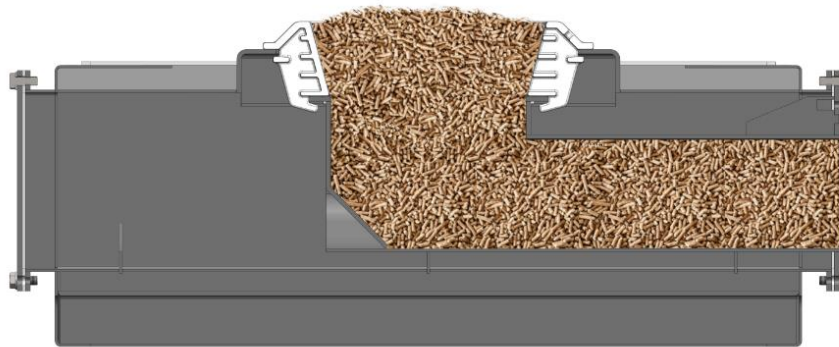

Slika 23. Prikaz nivoa peleta

- Sada kada imamo pelet u komori za sagorevanje i kada je on u zoni grejača za potpalu, možemo da startujemo početak rada kotla.
- Start se izvodi na sledeći način:

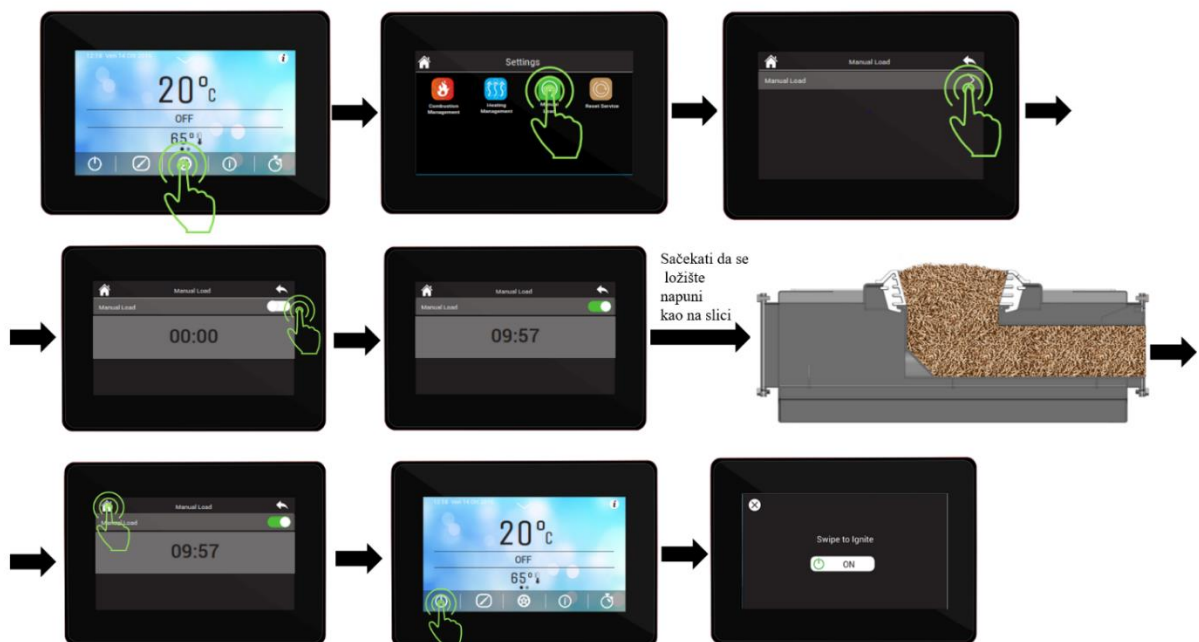

Slika 24. Postupak za ručno doziranje peleta, moguće samo u OFF režimu

- U trenutku kada kotao krene u potpalu na displeju piše **Check Up** i u ovih nekoliko sekundi radi samo ventilator. Za vreme ove faze automatika proverava da li su svi uređaji neophodni za rad zaista i priključeni.

- Sledeći korak je kada na displeju piše **Ignition**. Ovo je oznaka faze paljenja. Tada se osim ventilatora pali i grejač za potpalu što se može proveriti na automatici Homepage 2/2 slika. U fazi potpale po fabričkim podešavanjima se ne uključuje sistem za transportpeleta.
Postoji mogućnost u radu automatike da se umesto ručnog pre-doziranja koristi automatska doziranja podešavanjem parametra T03 u skrivenom meniju. Automatsko pre-doziranje se ne preporučuje jer je vreme koje je potrebno da se napuni ložište kao što je prikazano na slici 16 varijabilno i zavisi od više faktora uključujući i samu konstrukciju dimljaka pa čak i vremenske uslove (pritisak vazduha).
- Kotao je u fazi potpale sve dok dimni gasovi ne pređu temperaturu koja je određena parametrom **Th09**. Prema fabričkim podešavanjima ova temperatura je **50°**. Prvo se pojavi dim, a u periodu od 7 do 10 minuta i plamen.
- Kada dimni gasovi pređu graničnu temperaturu paljenja na displeju se pokazuje natpis **Stbilisation**. Ovo znači da je kotao u fazi stabilizacije plamena tj. sada automatika meri da li dimni gasovi imaju dovoljan prirast za određeno vreme. Ventilator radi prema parametru za fazu stabilizacije, a dolazi i do dopune ložišta peletom takođe prema parametrima puža u fazi stabilizacije. U trenutku kada je i ovaj faktor zadovoljen kotao ide u radni režim **RUN MODE**.
- Kotao je u radnom režimu kada na displeju **RUN MODE** osim trenutne temperature vode u kotlu. Treba sačekati od 20 do 30 minuta i videti da li pelet gori na vrhu komore za sagoravanje. Takođe u ovom periodu treba pratiti i kolika je temperatura dimnih gasova. Temperaturu dimnih gasova kao i drugi vitalni parametri se mogu očitati svakog trenutka pritiskom dugmeta i na glavnom displeju.
- Na automatiku može biti povezan sobni termostat na zahtev korisnika. U ovom slučaju, važno je podesiti temperaturu prostorije koja je glavni parametar za rad kotla i temperaturu vode u kotlu (70°C). Kada je aktiviran rad sobnog termostata, kotao najpre ima zahtev za postizanjem temperature sobe, stin da je ograničen zadatom temperaturom vode u njemu. Postoji mogućnost da kotao prestane sa radom pre zadate temperature sobnog termostata, u ovom slučaju treba podići zadatu temperaturu vode u kotlu npr.70°C.
- Sagorevanje peleta, bez obzira na snagu sa kojom kotao radi, neophodno je podesiti tako da je na vrhu prostora za sagorevanje. Ovo se postiže podešavanjem doziranja peleta i količine vazduha. U slučaju da nivo plamena počinje da se spušta, neophodno je da se produži vreme doziranja ili smanjenje količine vazduha. Ako želimo da smanjimo toplotnu moć, neophodno je da smanjimo količinu vazduha. Ako se desi da se nivo plamena podiže, možemo da smanjimo vreme nalaganja ili povećamo količinu vazduha. Za tačno određivanje parametara potrebno je pratiti proces rada najmanje sat vremena.

NAPOMENA: Uvek se treba pridržavati nominalne ili maksimalne snage sagorevanja peleta, tj. kada pelet sagoreva na vrhu gorionika. U ovom slučaju smanjenje toplotne moći vršimo smanjenjem zadate temperature vode u kotlu ili zadate temperature sobnog termostata.

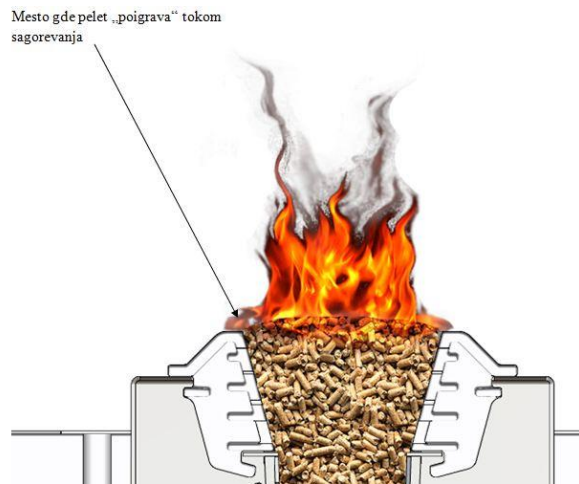

Slika 25. Prikaz idealnog sagorevanja peleta



Upozorenje: Obavezno izvršiti analizu dimnih gasova nakon završetka instalacije kotla. Izmeriti procenat kiseonika (O₂).

7.3. Kratko uputstvo za upotrebu automatike

7.3.1. Dopuna ložišta sa peletom, priprema za paljenje i start potpale na pelet

Postupak je prikazan na slici:

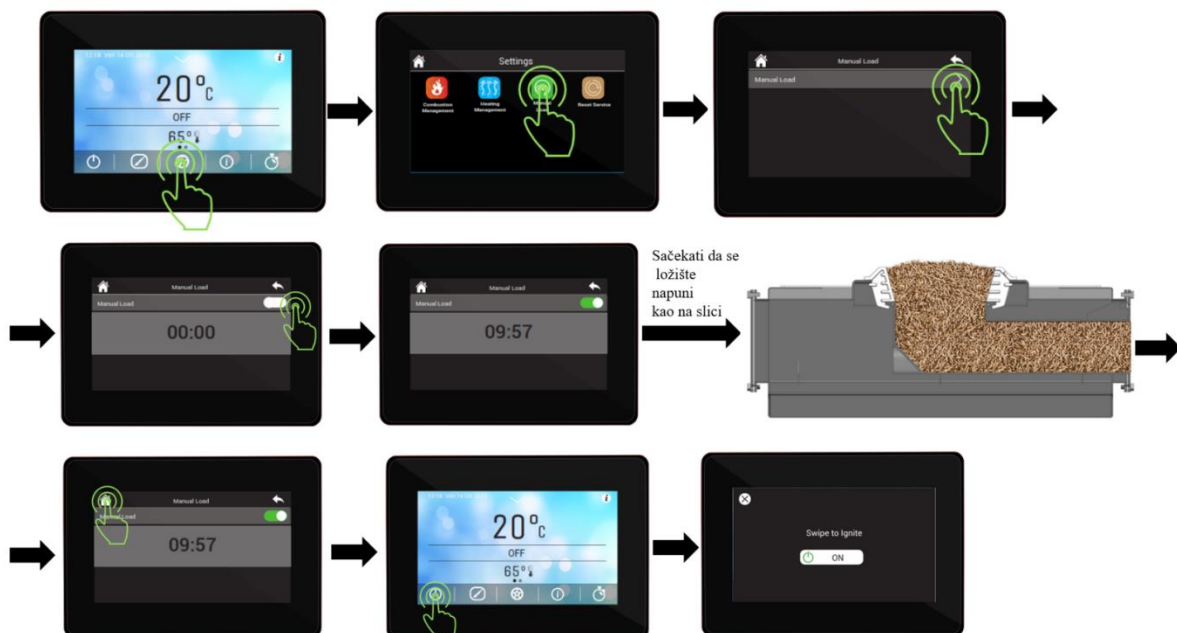

Slika 26. Start kotla

7.3.2. Promena vremena doziranja transportera u radnom režimu

Meni za modifikaciju radnog vremena i brzine sagorevanja dozera. 10 kalibracionih stepeni je moguće, 5 za uvećanja i 5 za umanjnje, vrednost 0 odgovara fabričkom podešavanju.

Promene u ovom meniju direktno utiču na snagu recept sagorevanja u Run Modu i Modulaciji. Za svaki korak podešavanja vrednost se povećava ili smanjuje za procentualnu vrednost P15 koja se može podesiti u skrivenom meniju. Ovaj meni je vidljiv samo ako je P11 različit od 1.

Primer: P15=10%, Step=-1

Osnovne vrednosti	CO3=2,0	CO4=3,0	CO5=4,0	CO6=5,0	CO7=6,0	C11=1,0
Kalibrisane vrednosti	CO3=1,8	CO4=2,7	CO5=3,6	CO6=4,5	CO7=5,4	C11=0,9

Tabela 4. Promena vremena doziranja transportera u radnom režimu

Izračunate vrednosti pripadaju opsegu definisanog parametrima P27 i P05.



Slika 27. Promena vreme doziranja pužnog transportera

7.3.3. Promena jačine ventilatora u radnom režimu

Sistem ima 10 kalibracionih sistema.

Promenu u ovom režimu utiču na trenutni recept i smagu rada u Run modu i modulaciji. Za svaki korak podešavanja vrednost se povećava ili smanjuje za procentualnu vrednost P16 koja se može podesiti u skrivenom meniju. Ovaj meni je vidljiv samo ako je P11 različit od 1. Kako izvršiti promenu prikazano je na slici.

Primer: P16=5%, Step=+3

Osnovne vrednosti	UO3=1000	UO4=1200	UO5=1400	UO6=1600	UO7=1800	U11=900
Kalibrisane vrednosti	UO3=1150	UO4=1380	UO5=1610	UO6=1840	UO7=2070	U11=1030

Tabela 5. Promena jačine ventilatora u radnom režimu



Slika 28. Promena jačine ventilatora u radnom režimu

7.3.4. Promena zadate temperature vode u kotlu

Meni za promenu željene temperature. Ograničen je minimalnom i maksimalnom vrednošću. Za promenu pratite sledeće korake.



Slika 29. Promena zadate temperature vode u kotlu

7.3.5. Kako očitati temperaturu dimovodnih gasova

Ako želite da očitajte temperaturu dimnih gasova pratite sledeće korake.



Slika 30. Očitavanje temperatur dimnih gasova

7.4. Greške prilikom startovanja kotla

Sve moguće greške u početnoj fazi rada tj. prilikom potpale mogu da se podele u tri velike grupe:

- **Grupa I.** Greške u potpali koje se odnose na situaciju kada nema pojave varnica, dima ni bilo kakvog plamena više od 20 minuta od trenutka kada se upalio grejač za potpalu.
- **Grupa II.** Greške u potpali koje se odnose na situaciju kada je došlo do pojave plamena ali se kotao posle izvesnog vremena (nekoliko minuta) ipak ugasio.
- **Grupa III.** Kotao je uspešno potpalio i radio nekoliko sati. Dostigao je zadatu temperaturu i duže vremena nema potrebe da se uključuje ni dozirni sistem ni ventilator (najčešće je ova situacija tokom noći). Zatim temperatura pada ili korisnik želi višu temp. (najčešće ujutru) i kotao dobija signal da krene u fazu potpale, ali do plamena ne dolazi.

Grupa I

Moguć **uzrok 1.**

- **PROBLEM 1** – Zatvorena klapna ventilatora za primarni vazduh. Ventilator se nalazi na dozatoru.
- Postupak za rešavanje **PROBLEMA 1** – Otvoriti klapnu ventilatora maksimalno.

Moguć **uzrok 2.**

- **PROBLEM 2** – Crevo koje spaja kanal vazduha od ventilatora do grejača nije pravilno postavljeno.
- Postupak za rešavanje **PROBLEMA 2** – Pričvrstiti crevo za vazduh i na kućište grejača i na cev kanala za vazduh.

Moguć uzrok 3

- **PROBLEM 3** – Prostor u dubini ložišta gde sagoreva pelet je pun nesagorelih ostataka odnosno šljake tako da nema dodira peleta i vrelog vazduha.
- Postupak za rešavanje **PROBLEMA 3** – Očistiti dubinu ložišta i to prvo krupniju šljaku mehanički, a sitniju je moguće pokupiti i usisivačem.

Moguć uzrok 4

- **PROBLEM 4** – Pelet koji se koristi je velike vlažnosti.
- Postupak za rešavanje **PROBLEMA 4** – Probati sa peletom koji je većeg stepena suvoće.

Moguć uzrok 5

- **PROBLEM 5** – Mrežni napon na koji je priključen kotao je znatno manji od 220-230V tako da je i snaga grejača manja.
- Postupak za rešavanje **PROBLEMA 5** – Priključiti mrežni ispravljač napona ili potpaliti ručno.

Moguć uzrok 6

- **PROBLEM 6** – Posle ručnog nalaganja i automatske dopune ložišta u fazi potpale nivo peleta je takav da pelet nije u kontaktu sa grejačem.
- Postupak za rešavanje **PROBLEMA 6** – Dopuniti nivo peleta.

Moguć uzrok 7

- **PROBLEM 7** – Prebačen je kotao iz automatskog u ručni režim rada. Ako tokom čitave faze potpale ne gori lampica za grejač onda smo sigurni da je kotao u ručnom režimu.
- Postupak za rešavanje **PROBLEMA 7** – Prebaciti kotao u automatski režim potpale.

Moguć uzrok 8

- **PROBLEM 8** – Neispravan elektro grejač za potpalu. Isključiti kotao iz mrežnog napajanja i na priključnim kablovima elektro grejača izmeriti omsku otpornost.
- Postupak za rešavanje **PROBLEMA 8** – Promeniti elektro grejač

Grupa II

Moguć uzrok 1.

- **PROBLEM 1** – Brzina ventilatora u fazi potpale. Brzina ventilatora za primarni vazduh u ovoj fazi je određena parametrima UC01. Ukoliko menjate ove parametre u odnosu na fabrički podešenu nije dobro ni značajno je smanjiti ni povećati. U slučaju kad je ventilator u potpali slab onda nema porasta temperatura dimnih gasova a ako je prejak može doći do brze potrošnje peleta u komori što opet dovodi do smanjenja temperature dimnih gasova u potpali.
- Postupak za rešavanje **PROBLEMA 1** – Podesiti vrednosti parametara UC01 na fabričke ili blizu fabričkih.

Moguć uzrok 2

- **PROBLEM 2** – Brzina ventilatora u fazi stabilizacije plamena. Kotao uđe u potpalu, pojavi se dim, na displeju piše Stabilisation što znači da je u fazi stabilizacije

plamena ali posle toga kotao se ugasi. Najčešće uzrok ovome je preslab ventilator u fazi stabilizacije što je određeno parametrom UC02.

- Postupak za rešavanje **PROBLEMA 2** – Pojačati brzinu ventilatora parametrom UC02.

Moguć uzrok 3

- **PROBLEM 3** – Previše ili premalo peleta u fazi stabilizacije. Ako ima malo ili previše peleta dok na displeju piše Stabilization tj. stabilizacija, može doći do zagušenja plamena i vraćanja kotla u stanje gašenja. Količina peleta u fazi stabilizacije se reguliše parametrom C02.
- Postupak za rešavanje **PROBLEMA 3** – vrednost parametra C02 na fabričku ili blisku fabričkoj.

Moguć uzrok 4

- **PROBLEM 4** – Kotao je ušao u fazu stabilizacije ali ide u fazu gašenja jer nema dovoljan prirast temperatura dimnih gasova. Naročito je stagnacija odnosno mali pad temperatura dimnih gasova uočljiv u trenutku kada kreće dopuna ložišta sa peletima.
- Postupak za rešavanje **PROBLEMA 4** – Podići temperaturu dimnih gasova za ulazak sistema u RUN MODE, a to je parametar Th09. Na taj način novi pelet koji ulazi u komoru za sagorevanje teže obara temp. dimnih gasova jer je plamen jači iz razloga što mu se dalo više vremena do trenutka dopunjavanja. Ovaj problem se najčešće javlja kad su slabi dimnjaci ili je vuča dimnjaka iz nekog drugog razloga slaba.

Moguć uzrok 5

- **PROBLEM 5** – Kotao je ušao u fazu stabilizacije ali posle izvesnog vremena ide u gašenje.
- Postupak za rešavanje **PROBLEMA 5** – Zaboravljena da se vrati u kotao ili potpuno zatvori fioka za pepeo.

Grupa III

Kada kotao dostigne zadatu temperaturu vode u njemu ili vazduha u prostoriji gde je sobni termostat, prelazi u fazu mirovanja, odnosno održavanja plamena ili u originalu Standby fazu. Najbolji primer za ovakav način rada kotla je noćni rad. Osnovni cilj ove faze je održati plamen odnosno žar u ložištu tokom višesatnog mirovanja. To se postiže periodičnim uključivanjem i pelet transportera i ventilatora u određenim periodima vremena.

U trenutku kada je kotao dostigao zadatu temperaturu on ulazi u fazu održavanja plamena. Ta faza ima dve podfaze pause i work. U fazi pause dozer je isključen i radi samo ventilator dimljače odnosno ciklon brzinom UA14. U fazi work krene malo sagorevanje u cilju održavanja žara, parametri su UA12, US12, UC12.

Moguće greške u radu vezane za fazu održavanja plamena:

- Kotao i pored funkcionisanja faze održavanja plamena nema dovoljno peleta za start i rad u normalnom režimu.
- Otklanjanje uzroka greške :

1. Smanjiti parametar T32, odnosno povećati učestanost rada transportera i ventilatora u fazi mirovanja.
 2. Povećati vreme trajanja procesa tj. parametar T33.
- Previše nesagorelog peleta pri kretanju kotla u rad.
 - Otklanjanje uzroka greške :
 1. Povećati parametar T32
 2. Smanjiti parametar T33
 3. Smanjiti snagu ventilatora za primarno sagorevanje u fazi održavanja plamena parametar UA14.

8. Održavanje kotla

Kotao TKAN zahteva svakodnevno i periodično čišćenje.

1. Svakodnevno (barem sedmično) čišćenje se odnosi i na prostor samog ozidanog ložišta od sivog liva gde stalnim izbacivanjem pepela omogućavamo bolji rad elektro grejača za potpalu i bolje sagorevanje tj. veću količinu vazduha kroz vazdušne kanale u sivom livu. Takođe pepeo već u toku dana počinje da se taloži na podu, prostoru oko samog ložišta. Pri prosečnim parametrima sagorevanja 100kg peleta proizvede 1kg pepela ali ovaj podatak znatno varira u zavisnosti od vrste i kvaliteta peleta.
2. Na svakih 7 do 10 dana preporučuje se gašenje kotla, njegovo hlađenje od nekoliko sati i ručno ili najbolje vakum usisivačem čišćenje dubine prostora komore za sagorevanje. Ovako se odstranjuju i krupniji komadi nepotpuno sagorelog peleta koji mogu da izazovu neprijatan zvuk tokom rada i da izazovu kraći radni vek pužne spirale koja gura pelet u prostor za sagorevanje.
3. Jednom u mesec dana potrebno je otvoriti i gornja vrata za čišćenje, izvaditi turbulatore i sa cevi izmenjivača ukloniti naslage katrana i čađi. Sve što se tada skine pokupi se na gornjoj površini krova ložišta ili u dimnoj kutiji. Previše pepela u cevima izmenjivača smanjuje iskorišćenje kotla i dovodi do previsokih temperatura u ložištu koje mogu da utiču i na njegove deformacije, naročito donjih vrata.
4. Čišćenje multiciklona treba obaviti jednom mesečno. Na bočnim stranama kućišta postoje dva otvora za čišćenje. Skinuti poklopac i detaljno očistiti unutrašnjost kućišta. Voditi računa prilikom vraćanja poklopca da se traka za dihtovanje ne pomeri. Takođe treba očistiti i centrifugalni ventilator koji na cevi ima otvor za čišćenje.
5. Bez obzira na automatsko otprašivanje neke delove treba očistiti ručno i to:
 - deo koji se nalazi ispod cevnih izmenjivača (vidi se kada se otvore gornja vrata)
 - po neku cev u izmenjivaču koja se nalazi u uglovima.
 - Čišćenje vršiti periodično, bar jednom mesečno.
 - Obavezno, jednom dnevno, ispuštati vodu iz rezervoara kompresora pomoću ventila koji se nalazi na dnu rezervoara.
 - Obavezno prazniti čašu u pripremljenoj grupi u kojoj se skuplja kondez (voda).
 - Ako je ugrađena jedinica B, obavezno, jednom dnevno, ispuštati vodu iz rezervoara pomoću ventila koji se nalazi na dnu rezervoara.
6. Čišćenje cevi grejača preporučuje se mesečno, čišćenje filtera grejača u ovlašćenom servisu.
7. Svake godine proveriti ispravnost turbine i po potrebi balansiranje (kada se radi redovan godišnji servis), a svake druge godine obavezno je balansiranje turbine.
8. Sigurnosni ventil je potrebno baždari po zakonu svake godine u ovlašćenju laboratoriji za baždarenje opreme.
9. Obavezno jednom mesečno da se proveriti ispravnost elektro grejača za potpalu Leistera, ako je tada potrebno očistiti cev gde se on postavlja.
10. Obavezno servisiranje kotla nakog završene grejne sezone.

Napomena: U zavisnosti od režima i uslova rada, kvaliteta peleta odnosno biomase navedeni periodi čišćenja mogu da budu i češći.

U koliko u kotlu, tokom korišćenja javi kondenzacija, potrebno je pokupiti kondenzat. Kotao iznutra premazati baznim sredstvima za čišćenje ili barem vodenim rastvorom građevinskog kreča. Na taj način se vrši neutralizacija kiselina usled kondenzacije.

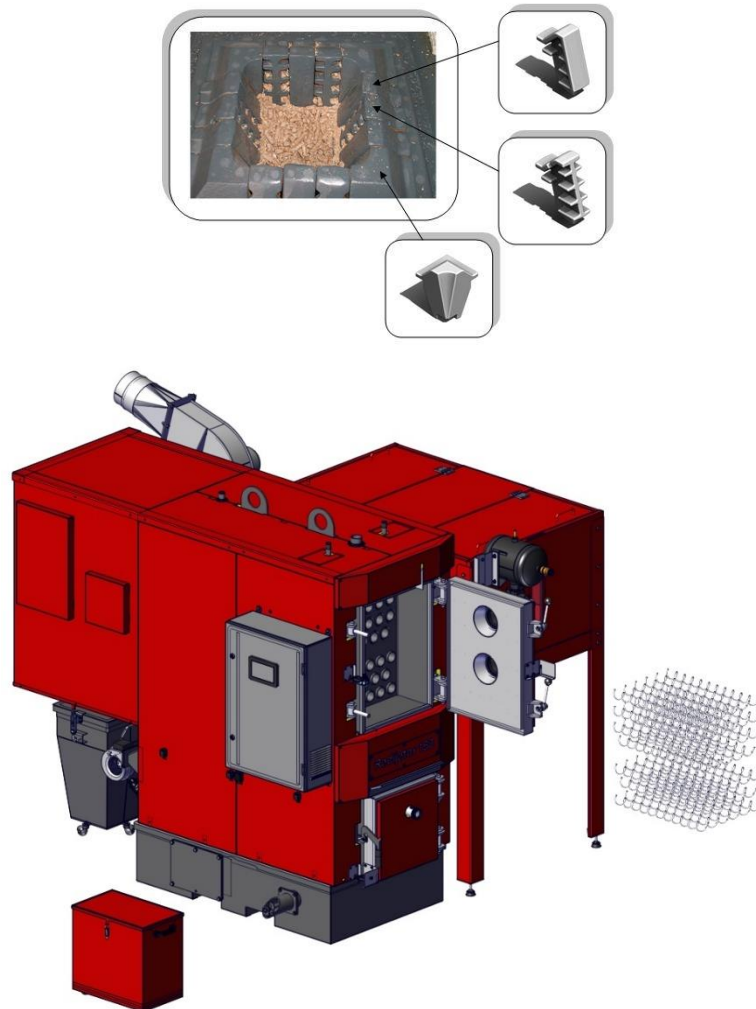

Slika 31. Prikaz vadjenja turbulatora iz kotla TKAN, demontaža livenih segmenata ložišta i čišćenje kante za pepeo



Na ovaj način obavezno konzervirati kotao na kraju grejne sezone. U toj situaciji zatvoriti i sve otvore na kotlu da ne dodje do cirkulacije vazduha kroz kotao jer i tako može doći do pojave vlage u kotlu.



Održavanje kotla je jedan od najbitni faktora za dužinu radnog veka kotla. Naročito je bitno da u vansezoni kotao bude očišćen i da se izvrši neutralizacija kiselina na već opisan način.

9. Garancija

1. Radijator inženjering pokriva različite garancijske periode za različite delove (što je navedeno u daljem tekstu) samo ako su ispunjeni sledeći uslovi garancije:

- Kotao mora biti priključen po navedenim hidrauličkim šemama iz tehničkog uputstva, naročito obratiti pažnju na sigurnosne ventile, termičko osiguranje oticanjem, mešajući ventil-pumpe za zaštitu hladnog kraja kotla odnosno protiv kondenzacije, opseg radnog pritiska kotla, opseg radne temperature kotla, uslove u kotlarnici itd. **(videti tačku 6.)**
- Kotao mora biti priključen na dimnjak propisanog poprečnog preseka, karakteristika izolacije i visine. **(videti tačku 3.3)**
- Dimovod od kotla do dimnjaka mora biti izveden po tehničkom uputstvu.
- Kod kotla moraju biti izvršena i navedena elektro priključenja iz tehničkog uputstva, naročito se misli na karakteristike sobnog termostata, karakteristike mrežnog napona koji mora biti u određenim granicama.
- Korisnik mora da se pridržava navedenih uputstava o korišćenju i održavanju. **(videti tačku 8.)**

2. Garancijska izjava

Izjavljujemo:

- Da proizvod ima propisana i deklarirana kvalitetna svojstva.
Obavezujemo se, da ćemo na zahtev kupca ako pravovremeno u garancijskom roku podnese zahtev za popravku, o svakom trošku izvršiti sve popravke kvarova, tako da će proizvod raditi u skladu sa deklariranim svojstvima,
- da će proizvod u garancijskom roku raditi besprekorno ako se budu poštovala uputstva za upotrebu, rad i montažu,
- da ćemo u garancijskom roku biti spremni da otklonimo sve kvarove na proizvodu i držati na zalihama sve potrebne rezervne delove,
- **garancijski rok počinje od DANA KUPOVINE I TRAJE 60 MESECI ILI 72MESECA OD DATUMA PROIZVODNJE (datum proizvodnje nalazi se na nalepnici sa zadnje strane kotla),**
- **GARANCIJA OD 60 MESECI VAŽI SAMO AKO SE KOTAO REDOVNO SERVISIRA OD STRANE CENTRALNOG SERIVISA RADIJATOR INŽINJERINGA u periodu naznačenom za isti (dalje u tekstu),**
garancija važi ako je garantni list overen od strane prodavca i ako je upisan datum kupovine i priložen račun. TAKOĐE BITNO JE IMATI I NALOG ZA PUŠTANJE U RAD. (overen od strane ovlašćenog servisa)

3. Garancijski period od godinu dana važi za sledeće delove:

- Za sve ležajeve serije UCFL,
- Elektro grejača za potpalu,
- Ležajeve ćelijastog sigurnosnog transportera (valvole),
- Ventilator na ciklonu (Ukoliko je nastalo oštećenje turbine I ventilator usled neodržavanja kotla troškove snosi kupac)

4. Garancijski period od dve godine važi za sledeće delove:

- motor reduktor,
- lance za prenos obrtnog momenta 083,
- donje pužne spirale,
- ventilator primarnog vazduha,
- ventilator sekundarnog vazduha,
- automatiku kotla sa sigurnosnim termostatom,
- sondu dimovodnih gasova,
- sondu temperature kotlovske vode.
- segmente za sagorevanje od sivog liva,
- elektro konektore,
- izolacijske materijale na vratima i otvorima za čišćenje,
- delove ćelijastog sigurnosnog transportera (valvole) koji su od sivog i nodularnog liva.

5. Garancijski rok ne važi:

- ukoliko se posle svake grejne sezone ne odradi redovan servis,
- za zamenu delova kod redovnog godišnjeg održavanja u skladu sa uputstvima,
- kod kvarova koje je načinio kupac zbog nestručnog rukovanja proizvodom,
- kod mehaničkih kvarova načinjenih prilikom transporta i prilikom korišćenja (čvrsti predmeti),
- ako je proizvod instaliran nestručno, suprotno važećim propisima iz tog područja,
- ukoliko se utvrdi da hidraulička šema nije urađena po preporukama firme „Radijator inženjering”,
- ako je kupac koristio proizvod iznad deklariranih svojstava i u normalnim okolnostima,
- ukoliko u izmenjivački prostor kotla dospe vazduh u kome ima vode i ulja
RADIJATOR INŽENJERING:
 - ne priznaje garanciju na kotao i na sistem za otprašivanje
 - ne snosi posledice mogućeg zaprljanja kotla ili eksplozije vodene pare što može da izazove materijalnu štetu i ljudske žrtve.

6. Garancijski rok prestaje da važi:

- ako se ustanovi da je kvarove otklanjala neovlašćena osoba ili neovlašćeni servis,
- ukoliko u izmenjivački prostor dospe vazduh u kome ima vode i ulja,
- ako kod popravke nisu bili upotrebljeni i ugrađeni originalni delovi,
- kad ističe garancijski rok.

7. Kod prijave kvarova obavezno je dati sledeće podatke:

- naziv i tip proizvoda,
- datum kupovine,
- fabrički ili radionički broj kamina,
- kratak opis kvara, odnosno nedostatka,
- tačnu adresu i kontakt telefon, mejl.

8. Redovan godišnji servis

Redovan servis se odrađuje na kraju svake grejne sezone u period od 15.4. do 31.8. i naplaćuje se utvrđenim cenovnikom firme “Radijator Inženjering”. Servisni postupak tehničkih lica koja obavljaju redovne godišnje servise, a koja su od strane proizvođača ovlašćena za to, obuhvataju sledeće operacije:



NAPOMENA: Serviser je dužan da pregleda sve navedene delove (sa liste) dozatora i izmenjivača, i ukoliko dođe do zamene bilo kojih delova na iste korisnik dobija gore navedenu garanciju kao i garanciju na još 12 meseci na telo kotla (izmenjivač). Garancija se može produžiti do 5 god. od datuma puštanja u rad. Servis i produženje servisa može da obavlja lice koje šalje centralni servis “Radijator inženjering”-a. Na nezamenjene delove posle odrađenog servisa garancija ne važi.

Servisni postupak:

1. Demontaža silosa za pelet od pelet transportera;
2. Demontaža pelet transportera od kotla;
3. Skidanje oba lanca, lančanika i ležajeva sa pelet transportera;
4. Demontaža segmenata sa sagorevanje od ložišta i čišćenje prostora ložišta ispod segmenata. Provera stanja segmenata i njegovog međusobnog zazora;
5. Čišćenje prostora cevi ložišta u kojoj se okreće donja pužna spirala;
6. Podmazivanje svih ležajeva gornje i donje pužne osovine i provera njihove ispravnosti. Ležaj ne sme da ima otežano okretanje ili naprsline na kućištu. U suprotnom ležaj se menja. Ukoliko se utvrdi da je do oštećenja ležaja došlo zbog upadanja čvrstog predmeta ili nagomilavanja prašine, zbog lošeg kvaliteta peleta, u pelet transporteru, Radijator inženjering naplaćuje vrednost ležaja. Ako je do oštećenja ležaja došlo zbog

- povlačenja plamena u sam pelet transporter i to iz razloga loše postavljenih parametara prilikom korišćenja, Radijator inženjering naplaćuje vrednost ležaja;
7. Skidanje lanaca sa obe strane vratila čeljustog sigurnosnog transportera (valvole) i provera ispravnosti ležajeva u valvoli. Ukoliko je okretanje ležajeva otežano, zameniti ležajeve sa obe strane. Ukoliko je do oštećenja ležaja valvole došlo zbog upada čvrstog tela koje nije iz samog kotla (zbog greške korisnika ili proizvođača peleta) Radijator inženjering naplaćuje vrednost ležajeva;
 8. Proveriti oštrinu ivica rotora;
 9. Izvaditi sondu dimnih gasova i očistiti je od naslaga;
 10. Provera ventilator primara i sekundara i ventilator na ciklonu ukoliko se ciklon kao dodatna oprema nalazi na kotlu;
 11. Provera dihtovanja gornjih i donjih vrata;
 12. Provera održavanja kotlovskeg izmenjivača;
 13. Provera ispravnosti sistema za oprašivanje ukoliko se sistem za oprašivanje nalazi na kotlu kao dodatna oprema;
 14. Provera stanja ciklona na kotlu u koliko se ciklon kao dodatna oprema nalazi na kotlu;
 15. Provera stanja spirali za čišćenje i motor reduktora na istim;
 16. Provera ispravnosti fena za potpalu;
 17. Proveriti stanje cevi i filtera grejača i očistiti
 18. Proveriti rad turbine ventilator, a svake druge godine izvršiti balansiranje turbine.



RADIJATOR-Inženjering d.o.o

Živojina Lazića Solunca br.6
36000 Kraljevo
telefoni za kontakt:
036/399-140, 399-150
e-mail: radijator@radijator.rs

GARANTNI LIST / GUARANTEE LIST

Tip kotla / Boiler type

Fabrički broj / Factory

Garantni rok / Guarantee period

60 MESECI / 60 MONTHS

**Datum proizvodnje /
Date of manufacture**

**Potpis ovlašćenog lica /
Signature of Authorized**

____ pečat / stamp

Prodato u firmi / Company of Sale

Adresa / Address

Telefon /

Datum prodaje / Date of Sale

Potpis / Signature

*Potrošač ima sva prava na osnovu Zakona o zaštiti potrošača ("Sl. glasnik RS", br. erbia62/2014). Garancija ne isključuje niti utiče na prava potrošača koja proizilaze iz zakonske odgovornosti prodavca za nesaobzirnost robe u ugovoru. The consumer shall exercise all rights under the Consumer Protection Law ("OJ of RS" No 62/2014). The guarantee does not exclude nor affect the consumer's rights derived from the legal liability of the seller for any lack of conformity of the goods under a Contract.

*Gore navedeno važi za kupce na prostoru Republike Srbije. The aforementioned applies to purchasers of the Republic of Serbia.

Table of Contents

1. Important warnings.....	49
1.1 General Warnings	49
1.2 Important warnings.....	49
1.3 The minimal distance from flammable materials	50
2. Description of the boiler	51
2.1. Construction	51
2.2. Dedusting or automatic cleaning of the pipe bundles of the exchanger.....	52
2.3. Cyclone.....	52
3. Installation.....	55
3.1.General warnings.....	55
3.2 Boiler room.....	56
3.3 Connecting to the chimney	58
3.4. Dedusting.....	60
3.5. Installing multi cyclone	62
4.TKAN Integra cross-section	64
5.Table with dimensions	67
6.Hydraulic diagram	68
7. Explanation on how to use TKAN automatic controls	69
7.1 Automatic controls display.....	70
7.2. Starting the operation of th biomass boiler.....	77
7.3 A short guide to using automation.....	80
7.3.1. Filling the firebox with pellets	80
7.3.2. Changing the dosing time of the transporter in the operating mode	81
7.3.3. Changing the power of the fan in the running mode	81
7.3.4. Changing the set water temperature in the boiler	82
7.3.5. How to read the flue gas temperature.....	83
7.4. Errors while starting the boiler	83
8. Boiler's maintenance	87
9. Warranty	89

1. Important warnings

1.1. General Warnings

- Upon removing the package, make sure that the delivery is complete and, in case that something is missing, refer to the seller who sold the boiler
- The boiler must exclusively be used for the purpose intended by the seller. No responsibility will be taken by the manufacturer for the damage caused to people, animals, or things in case of installation errors, regulation, maintenance, or improper use.
- In case of water leakage, remove the device from the electric power supply, stop the water supply, and inform the licensed service department or the licensed fitter.
- This manual is an integral part of the device and has to be kept with care and **ALWAYS** has to come with the device in case of changing owner or user, or in case of being connected to another installation. In case of being damaged or lost, request a new copy from the licensed seller.

1.2. Important warnings

We remind you that, while using the device on biomass or solid fuel and those in contact with electricity and water, it is required to follow safety measures:

- ⚠ It is forbidden for children and persons with certain limitations without supervision to use the boiler
- ⚠ It is forbidden to use the boiler on installations with an operating temperature higher than 90°C and operating pressure higher than 3 bars.
- ⚠ It is forbidden to use easily flammable fuels (alcohol, oil) for the purpose of faster combustion of wood
- ⚠ It is forbidden to store highly flammable materials near the boiler and furnace doors. Ash must be stored in sealed and inflammable containers.
- ⚠ It is forbidden to incinerate waste and materials whose combustion produces flame or explosion hazards (e.g. plastic bags, sawdust, coal dust, mud, etc.)
- ⚠ It is forbidden to perform any kind of intervention by the technician or cleaning before the boiler is removed from the electric power supply by removing the outlet from the electric network
- ⚠ It is forbidden to alter safety elements. A periodical inspection of safety elements is mandatory according to the laws of the country where the boiler was installed.
- ⚠ It is forbidden to close ventilation openings in a room where the boiler is. Ventilation openings are necessary for proper combustion
- ⚠ It is forbidden to expose the boiler to extreme weather. The boiler itself is not intended to be installed externally and does not have an anti-freezing system
- ⚠ It is forbidden to shut down the boiler if the external temperature might drop below ZERO (freezing hazard)
- ⚠ To supply large industrial TKAN series boilers with electricity, three-phase electric energy is used. If the user uses generator units that turn on when electricity goes out, it is necessary to check if electric motors for transporting pellets have the same

direction as when they are on the mains power supply. If motors are operating in opposite directions, great damages to the boiler may result.

1.3. The minimal distance from flammable materials

- Ensure the appropriate distance from flammable materials and, if necessary, provide their protection.
- The minimal distance from flammable materials is regulated by law – please seek information from professionals whose profession is heating and chimneys.
- The minimal distance between the boiler and flue gas discharge pipes from the materials of low and average flammability rate should be at least 100mm.
- The minimal distance from easily flammable materials is 200mm and the same applies to materials of an unknown flammability rate.

Fire hazard!

- Storing flammable materials and liquids close to the boiler is forbidden.
- It is mandatory to inform users of the necessary minimal distance between flammable materials and the boiler.

A ... inflammable	asbestos, stone, building stone, ceramic wall tiles, terracotta, stucco, glazed concrete (without organic additives)
B ... not easily flammable	drywall, glass fibers, and isolation panels (AKUMIN, IZOMIN, RAJOLIT, LIGNOS, VELOKS, HERAKLIT)
C1... slow burn rate	beech and oak wood, composite wood, felt, and isolation panels (HOBREKS, VERZALIT, UMAKARTA)
C2 ... average burn rate	pine wood, larch wood, and fir wood, composite materials
C3 ... easily flammable	asphalt, cardboard, cellulose materials, particleboard, cork, polyurethane, polystyrene, polypropylene, polyethylene, floor fibers

2. Description of the boiler

The goal of developing the TKAN Integra boiler was such that RADIJATOR INZENJERING could offer the boiler to the market which is, according to its mechanical and thermal properties, distinctly intended for biomass fuel.

Using the general term 'BIOMASS', it is, of course, thought of pellets, but the possibility of firing with fruit pits, more precisely sour cherry and sweet cherry, should be pointed out as well. **If the user wants to use some unlisted form of biomass, the construction and development department of Radijator inzenjering, or the licensed seller should be contacted, because some specific types of biomass require special, specific combustion solutions.** While using mentioned fuels, the automatic control of main operation parameters is implied. With all listed examples of using biomass, a certain degree of fuel aridity is required.

Industrial boilers TKAN Integra series are manufactured in the following powers: **TKAN 80 Integra, TKAN 100 Integra, TKAN 150 Integra, TKAN 200 Integra, TKAN 250 Integra i TKAN 300 Integra.**

2.1. Construction

Speaking of the external design, furnace dimensions, firing and cleaning holes, TKAN preserved all good characteristics of previous models which distinguish RADIJATOR INZENJERING on the market.

The water part of the boiler, its method of exchanging heat between flue gases and water through the pipe exchanger, is adapted to biomass. Because of the fan, more precisely forced draft, the route of flue gases is longer than in standard boilers. Due to the same reasons, it is possible to flue gases deflectors, so-called turbulators that further increase the degree of utilization of the boiler. Turbulators are spirals made of pipe-like material.

The degree of utilization on pellets exceeds 90%. Values of the flue gasses can be read on the display of the boiler (see section 7.4.7).

Industrial TKAN boilers **have** the exchanger made of seamless pipes for the installation of **vents for thermal leakage protection**. All parts of the water part of the boiler are made of seamless pipes (quality **ST 35.4**) and at least 5mm thick boiler sheets depending on the power of the boiler. Sheets are **1.0425 EU** standard (speaking of quality), more precisely **P265GH** standard **EUII**

According to its principle of operation, the furnace is the so-called 'spring', where the fuel from the transport zone goes vertically upwards, that is springs to the combustion zone. It is made of massive insulation materials and grey cast iron.



It is necessary to clean the area around the burner.

Advantages of masonry boilers in comparison to non-masonry ones are the following:

- emissions of harmful gases are minimal;
- the emission of dust is reduced;
- fuel usage is maximum;
- the working life of the boiler is extended because the metal sheet isn't directly exposed to flame.

The transport of fuel is ensured via screw feeders. Fuel comes from the 457-1610 liters capacity silos depending on the size of the boiler..

In case it's needed, it is quite easy to disassemble the entire assembly into three independent units: a silo, a firing mechanism, a boiler with a furnace.

Speaking of the furnace, it should be noted that boilers from the TKAN Integra line have a sub-assembly intended for the AUTOMATIC CLEANING OF THE SPACE AROUND THE BOILER'S FURNACE. Boilers from the TKAN Integra line have one screw axle with a motor for cleaning ash from the furnace as shown in Picture 1.

2.2. Dedusting or automatic cleaning of the pipe bundles of the exchanger

 **The TKAN 80 Integra and TKAN 100 Integra models do not have an integrated dedusting system.**

TKAN 80 Integra and TKAN Integra models do not have an integrated dedusting system. Cleaning the exchanger is automatic by using compressed air. The dedusting of the boiler implies the automatic cleaning of the boiler from soot by using compressed air. The entire system is comprised of the following: a compressor unit, an air tank, and a dedusting unit. The whole principle of work is based on the rapid injection of compressed air through holes on the door in order to clean smoke pipes from soot. The automatic initiation of pulse valves is factory set and one by one is initiated at certain time intervals. On the upper door, a micro switch is also installed and, in case of opening the upper door, it instantly aborts the dedusting function. After closing the upper door, the micro switch activates and the automatic dedusting starts..

 **Besides the automatic cleaning, of course, it is necessary to occasionally clean the exchanger manually.**

2.3. Cyclone

 **To keep releasing dust particles from flue gases minimal, models TKAN 80 Integra and TKAN 100 Integra have one fan installed on the chimney, while models TKAN 150 Integra, TKAN 200 Integra, TKAN 250 Integra, and TKAN 30 Integra have a constructed multi cyclone with a centrifugal fan.**

 **Occasionally, it is necessary to clean the cyclone as well through appropriate inspection holes.**

Seven multi cyclones with a centrifugal fan can also reduce the required chimney height. The multi cyclone is a cluster of numerous small diameter cyclones installed to a mutual case. Flue gases are introduced tangentially near the top of the cylindrical part of the cyclone, and because of the action of the centrifugal force, the outcome is the separation of particles from gas that reach the cyclone's walls. By the action of weight force, separated particles spirally travel downwards along the cone-shaped part of the cyclone into the container. Cleansed gas's current spirally flows out through the submerged pipe of the cyclone into the atmosphere or pipe system. In Picture 7, basic parts of the multi cyclone are displayed: a case, a body, and a container.

A very important notice in terms of the construction of TKAN industrial boilers is that it allows additional equipment as well.

Additional equipment elements are:

Bigger daily silos that come with the boiler. Standard silos (Picture 2) are listed in the dimensions table, however, if a buyer has more space in a boiler room and wants a bigger, so-called daily silo with special dimensions, it is possible to order such a silo made by *Radijator inzenjering*. The delivery of such a silo is possible even after a boiler is in a boiler room.

Multi-day pellets storage containers. It is also possible to deliver silos (a capacity of tens of tons) and which are connected to a small daily silo with a screw feeder. Loading these silos is done from the so-called one-ton jumbo bags by a bucket elevator. This equipment can be delivered separately as well.

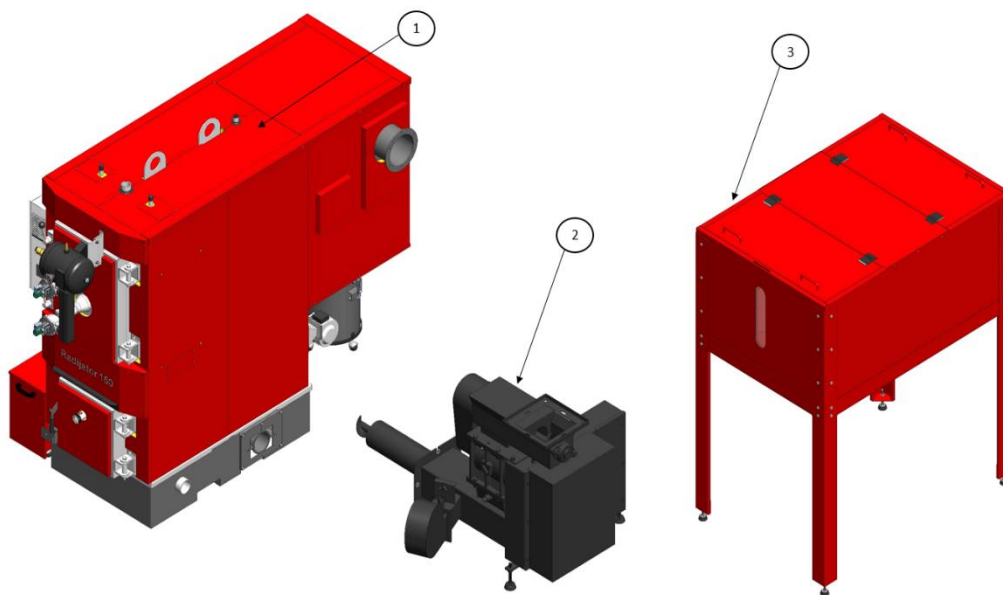

Picture 1. The representation of the disassemblable boiler units

1. Boiler
2. Dispenser assembly
3. Silo

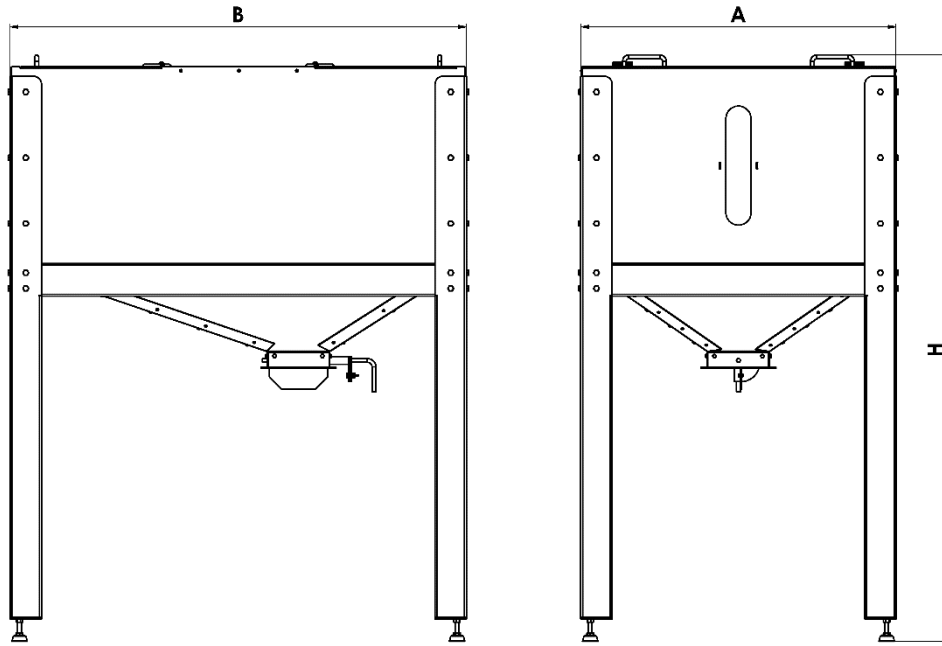

Picture 2. Standard silo for TKAN boilers

	DIMENSIONS				
	A	B	H	V	Pellet capacity
	mm			liters	kg
TKAN 80 Integra	606	1020	1736	290	180
TKAN 100 Integra	1006	1456	1872	680	410
TKAN 150 Integra	1006	1456	1872	680	410
TKAN Integra 200/250/300	1394	1830	1822	1600	1000
	1394	1830	2130	2330	1500
	1394	1830	2445	3115	2000

Tabel 1. Silo dimensions

Boilers TKAN Integra 200/250/300 provide a possibility to have one of three silo variants installed in the boiler room, depending on the buyer's preference of course. Template measures are given in table 1..

3. Installation

3.1. General warnings



Before initiating the boiler, make sure that the direction of a pellets feeder system's motor is such that it provides pellets supply into the furnace. Also, if a power outage happens while using generators, check if the direction of the motor is such that pellets go directly into the firing chamber. On the contrary, permanent boiler damages may occur.



TKAN boilers are intended for the maximum working pressure of 3 bars and maximum working temperature of 90°C, therefore they fit into the category of hot water boilers. Operating at higher values than listed can cause great material damages and endanger human lives.



It is strictly forbidden to reduce the cross-sections of safety lines. Also, it is strictly forbidden to install safety equipment whose working pressure is higher than 3 bar. It is recommended to install a thermal leakage valve in accordance with the law of the country in which the equipment is installed.



The boiler has the fan, automatic controls system, the pellets transport mechanism eventually the furnace or pipe bundle cleaning mechanism. All these devices use a 230V or 3x380V power supply, therefore improper installation and careless handling can endanger human life by electrocution. The boiler has the fan, automatic controls system, the pellets transport mechanism eventually the furnace or pipe bundle cleaning mechanism. All these devices use a 230V or 3x380V power supply, therefore improper installation and careless handling can endanger human life by electrocution.



During each intervention on the boiler's electric system (e.g. changing electric heater for firing, electric gear motor interventions or fan interventions, etc.) it is mandatory to shut down the main power supply by disconnecting the socket from the network installation. This way, possible electric shocks and endangering lives of technicians performing the intervention are avoided.



Solid fuel and forced draft boiler should be installed according to valid norms and law regulations. Every change either on the mechanical construction or on the electrical installation will be considered a violation of warranty terms and lead to their violation.

While bringing the boiler into the boiler room, it is very frequent that the entire boiler cannot fit through the existing door or some other object in the boiler room represents an obstacle. In such situations, it is very easy to disassemble the boiler into three basic assemblies:

- water exchanger with furnace;
- pellets transport mechanism;
- silo.

Also, the position of the silo is assembled in the wrong way, it is very easy to disassemble and reassemble three aforementioned assemblies and achieve the desired structure of the boiler.

Basic requirements that should be met while assembling:

- While setting up the boiler pay attention to its side and rear side's distance from possible obstacles. That way, it will be possible to approach in order to clean ash from the boiler or to, eventually, disassemble the pellet feeder.
- The boiler can be connected to the open vented central heating system, but to the sealed central heating system as well. If we are talking about the sealed central heating system, it is recommended to install a thermal leakage protection valve, which is regulated by appropriate laws of each county where the boiler is being installed. To install these valves on the boiler itself, there are corresponding connections.
- If there are frequent power outages in the potential boiler room, use additional measures for the safety and protection of the boiler. If there are installation parts that are 'submerged', that is on a lower level of the boiler and some heating bodies, it is suggested to choose an open vented central heating system. The boiler has to be placed at a safe distance from highly flammable materials.
- The electric power supply for the boiler is 3x380V (except for TKAN80 Integra – all power consumers are single-phase) and 50Hz, and the connection of all included parts priključenje should be done according to all valid regulations and is done by a person with appropriate permission.
- Connection to a chimney is also done according to obligatory regulations as well as recommendations from a manufacturer as it is written in the following text.

3.2 Boiler room

The boiler room must be secured against freezing.

The boiler base in the boiler room has to be made of inflammable material. Recommended distances of all four sides of the boiler in relation to the walls of the boiler room or some other rigid bodies (storage boiler, etc.) are shown in picture 3.

These distance values enable a safe approach while firing, sufficient space for cleaning, and free approach to the fan, pellets feeding mechanism, electric heater for ignition, and valve for charging and discharging. The space for handling the ash box should be provided.

From the silo's side, there should be a distance from 400mm to 900mm (measured from a wall) depending on the boiler's power. Those measures are given in the following text in the

table for every power. This space is needed in case of any bigger interventions on the pellets feeder mechanism, 11, more precisely when it should be dismantled from the boiler. The space at the back of the boiler (TKAN 80 and TKAN 100 Integra) needs to provide easy access to a chimney and ash cleaning holes on it. Speaking of other boilers in this line, the space at the back should enable handling the multi cyclone. In front of the boiler, it is necessary to ensure easy opening of all doors and space for dedusting elements.

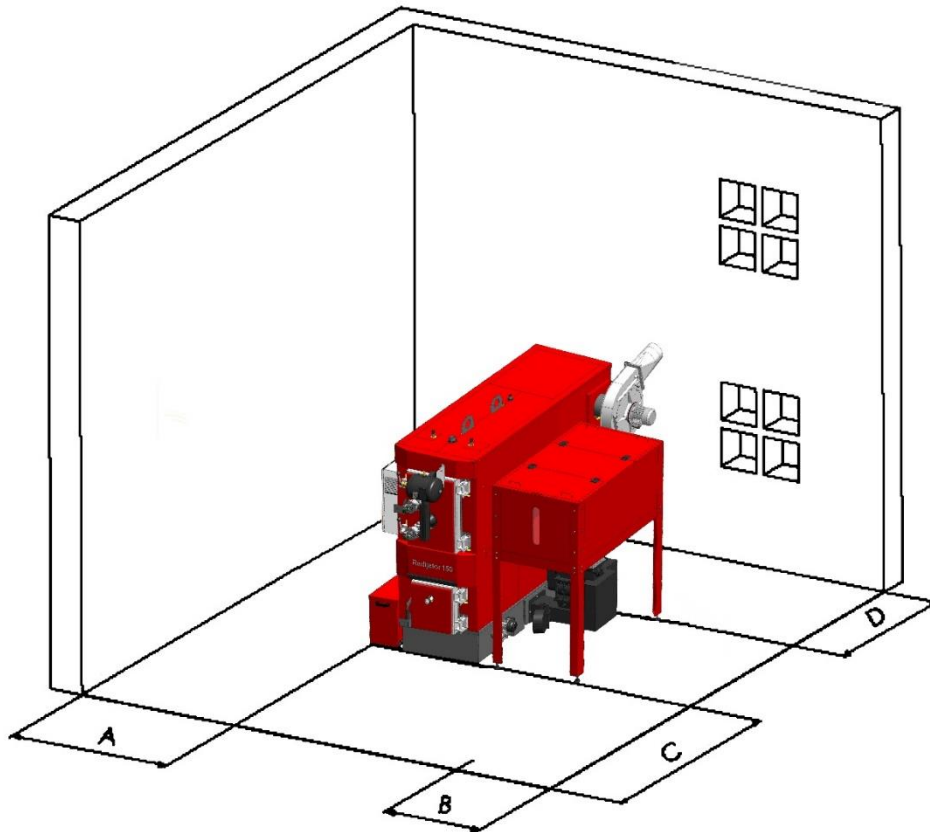

Picture 3. Positioning the boiler in the boiler room

Boiler type	DIMENSIONS			
	A* (mm)	B (mm)	C (mm)	D (mm)
TKAN 80 Integra	500	400	1000	800
TKAN 100 Integra	500	400	1000	800
TKAN 150 Integra	500	550	1000	1000
TKAN 200 Integra	600	650	1000	1000
TKAN 250 Integra	600	900	1000	1100
TKAN 300 Integra	600	900	1000	1100

Tabel 2. Positioning the boiler in the boiler room

NOTICE: All boilers have one semi-automatic spiral for cleaning the space around the furnace. Automatic dedusting system. TKAN 80 Integra and TKAN 100 Integra have a chimney with a fan while higher power boilers have pre-installed multi cyclone.

The boiler room must have necessary ventilation, that is, openings big enough for the fresh air to enter and exhaust air to leave.

The total surface of these openings is a minimum of 200cm² for power up to 80kW and for power over 80kW the surface has to be larger by another 2cm² per kW.

$$A = 200 \text{cm}^2 + \frac{2 \text{cm}^2}{\text{kW}} \times (\sum Q_n - 80 \text{kW}) \quad \sum Q_n = \text{moguće snage preko 80kW.}$$

The lack of sufficient ventilation in the boiler room can cause numerous problems in the operation of the boiler. The main problem is the inability to achieve high outgoing water temperatures, that is, not achieving maximum power leading to condensation in the boiler.

- Take into account the necessary minimum space required to access the safety elements and to execute cleaning and service operations of electrical and mechanical components.
- Make sure if the degree of electrical protection is in accordance with the characteristics of the room where the boiler is to be placed.
- It is forbidden to expose the boiler to extreme weather conditions. The boiler itself is not intended for external mounting and does not have an anti-freezing system.
- It is forbidden to close the ventilation openings in the room where the boiler is located. Ventilation openings are necessary for proper combustion.

3.3 Connecting to the chimney

The most optimal placement of the boiler on the chimney is such that the line connecting the center of the exiting point of flue gases from the boiler and the center of connection point to the chimney is in a slight rise (up to 3%) (see picture 4).

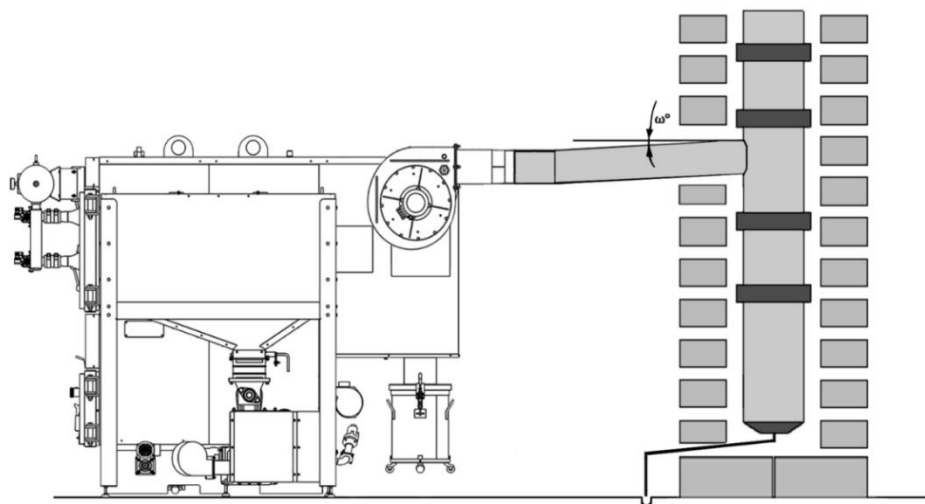

Picture 4 - The representation of how to connect to the chimney

If possible, avoid arches, and if it is not possible, the maximum number of arches is 2. It is advisable to isolate the smoke channel from the boiler to the chimney, especially if there are arches and longer sections. On a smoke pipe, approximately 100mm from the boiler's chimney, a hole should be made and an insert for a flue gas temperature probe insert should be installed. Without information on flue gases temperature, there is no automatic operation mode of the boiler.

The chimney itself should be made of ceramic pipes, there should be 3 - 5 cm thick insulation around them and the final outer layer is brick or special chimney elements. If the chimney is not made of ceramics though, but of brick, the surface of the light section of such a chimney must be 30% larger than this area of the ceramic chimney.

The chimney must also have a cleaning door and they must seal well. The chimney exit on the roof has to be in accordance with certain regulations. There are two different cases: if the angle of the roof is smaller than 12° and if the angle of the roof is greater than 12° . For an angle smaller than 12° , the height of the chimney above the roof is 1m and for an angle greater than 12° . see picture 5.

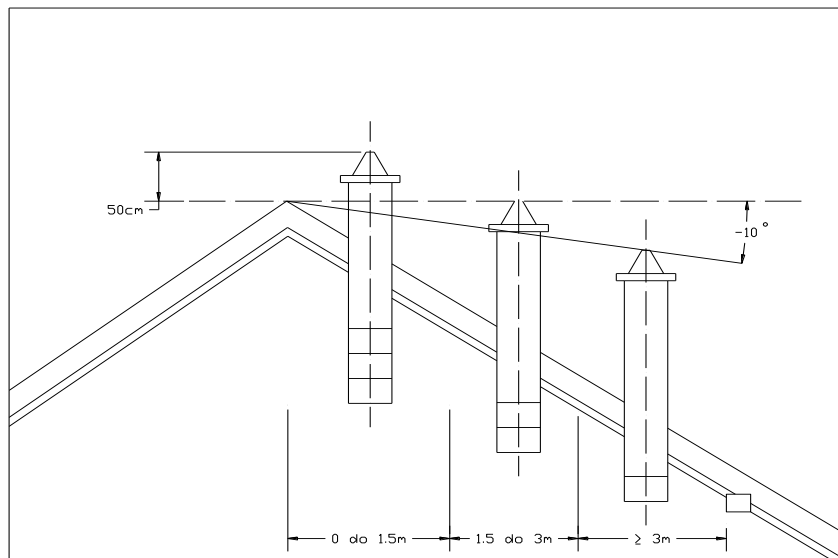

Picture 5. Height of the chimney

If you think that the chimney is too powerful and that too much cold air flows through the boiler, at the exit of the boiler there is a flap that can reduce the flow of exhaust gases. The chimney needs to be cleaned regularly or at least once a year.



If the chimney is not of the correct height, cross-section, or if it is not cleaned, complications in boiler operation might occur. First of all, a high-temperature mode of operation is not possible, i.e. there is no maximum operating power, the consequence of this is the occurrence of condensation which affects the service life of the boiler.



A weak chimney is the main reason for having a smoke on the upper or lower door, especially at higher fan speeds during the ignition or during operation of the boiler.



If there is too much smoke on the door and in the boiler room during the ignition of the boiler, or the flue gas temperature does not rise enough for the boiler to start operating and all because of the insufficiently strong chimney, it is technically justified to remove the wire turbulators from the pipe exchanger.

3.4. Dedusting

Dedusting implies the automatic cleaning of the boiler from soot by using compressed air. In order to achieve effective dedusting, it is necessary to do the whole installation by following regulatory standards for this area. It is necessary to select an appropriate compressor, provide quality air, and the appropriate amount of air to run a valve which insert air under pressure into the boiler.

The entire system is comprised of three units as seen in Picture 6:

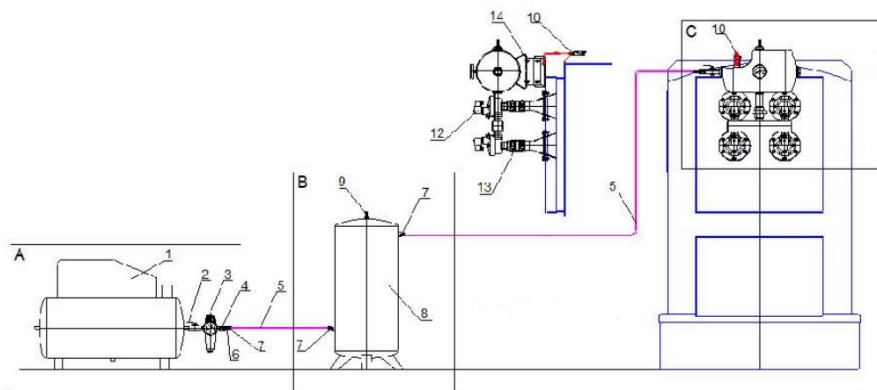

Picture 6. Dedusting system

- **UNIT A** - compressor unit
- **UNIT B** – rezervoar vazduha*
- **UNIT C** - otprašivačka jedinica

Unit A:

Obtained by a buyer.



In order to validate the warranty issued by a seller, it is necessary to acquire the compressor unit that meets the following conditions:

- The compressor has to have minimum airflow of 200 L/min

- Maximum pressure from 9 bars to 10 bars
- The compressor has to have minimum airflow of 200 L/min
- the FRL unit that meets ISO standard ISO 85731, class 14.1 (separation of solid particles, moisture and oil)
- Manometer



1. It is mandatory to release water once a day from the compressor's tank by using valve at the bottom of the tank.



2. It is mandatory to empty the bowl of the FRL unit where condensation (water) accumulates. If a compressor does not have a tank of 200l in capacity.

Unit B:

Obtained by a buyer.

* Ensure at least the 200l tank. For the purpose of continual air supply for the unit C.

***This is necessary only if the compressor does not have its own tank of at least 200l. This tank has to be certified to working pressure of 10 bars, test pressure of at least 13bars and has to have safety valve on it set tuned to 10 bars. It can be horizontal or vertical.



The air tank and safety valve have to be certified. The user of the equipment under pressure is obliged to control the tank and safety valve, regulated by the examination and inspection rulebook for the equipment under pressure.



It is mandatory to release water from the tank daily by using the valve located at the bottom of the tank.

Unit C:

is an integral part of the boiler and is comprised of:

- the air tank,
- the tank carrier,
- the safety valve,
- the relief valve 1/2",
- the manometer 1/4",
- the quick-release coupling 1/2" SN,
- the connection for quick-release coupling 1/4" UN,
- the connection for the hose 10/8 1/4" SN,
- the pulse valves carrier,
- pulse valves 6/4",
- connecting elements (clamps, rubber hoses, and connections),
- micro switch.



The air tank and safety valve must be certified. The user of pressure equipment is obliged to perform the control of tanks and safety valves, which is regulated by the rulebook on inspections and testing of pressure equipment.

All elements of unit C are provided by a manufacturer:

For TKAN 80 Integra and TKAN 100 Integra, it is not recommended to install the dedusting valves and they are not pre-integrated.

For TKAN 150 Integra a 10l tank and two pulse valves are delivered.

For TKAN 200 Integra, TKAN 250 Integra, and TKAN 300 Integra a 24k tank and a four pulse valves are delivered.

Operation principle:

The operation principle of unit C is based on rapid ejection of compressed air through holes on the door to clean smoke pipes from soot properly. Automatic initiation of pulse valves is pre-set and is initiated one by one at certain time intervals. The micro switch is also installed on the upper door that will, in case of opening the upper door, abort dedusting function instantly. Once the upper door is closed, the micro switch is activated and the automatic dedusting initiates. The air tank and safety valve hasve to be certified. The user of the equipment under pressure is obliged to control the tank and safety valve, regulated by the examination and inspection rulebook for the equipment under pressure.

3.5. Installing multi cyclone



Models TKAN 80 Integra and TKAN 100 Integra do not have the pre-integrated cyclonebut they have the fan on the chimney.

In order to reduce the emission of dust particles from flue gases, it is recommended to install the multi cyclone and the centrifugal fan. By installing it, it is simultaneously possible to reduce the required height of the chimney. With the multi cyclone and the fan, it is necessary to install boiler regulation as well. The multi cyclone represents a group of many cyclones smaller in diameterthat are set in the mutual case.

Flue gases are introduced tangentially near the top of the cylindrical part of the cyclone, and because of the action of the centrifugal force, the outcome is the separation of particles from gas that reach the cyclone's walls. By the action of weight force, separated particles spirally travel downwards along the cone-shaped part of the cyclone into the container. Cleansed gas's current spirally flows out through the submerged pipe of the cyclone into the atmosphere or pipe system.

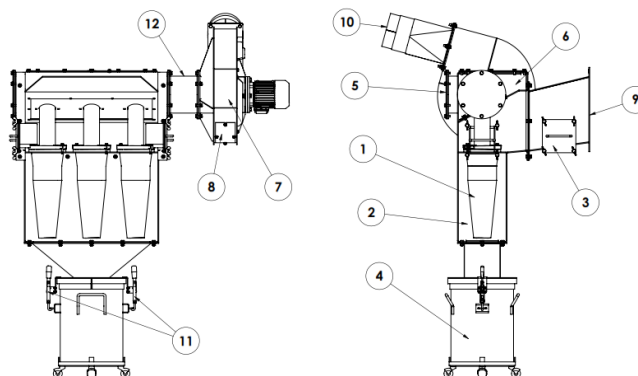

Picture 7. Schematic diagram of a multicyclone

- 1 Cyclone
- 2 Body of multi cyclone
- 3 Cleaning hole
- 4 Storage
- 5 Alternative fan carrier
- 6 Multi cyclone case
- 7 Centrifugal fan
- 8 Cleaning hole
- 9 Entering hole for flue gases
- 10 Exit hole for purifiedgases
- 11 Opening mechanism
- 12 Centrifugal fan carrier

Picture 7 shows the main parts of the multicyclone, which are: the housing, the body and the container.

The case has a certain number of smaller diameter cyclones inside and that is the most vital part of the multi cyclone. It is equipped with three connections to which the centrifugal fan can be connected. Two of them are located on the sides, and one is at the back of the case. On the sides, there are holes for cleaning the cyclone.

The body of the multi cyclone directs bigger particles into the storage.

The storage is used to collect larger particles extracted from flue gases. It has the opening mechanism that serves to separate the storage from the body in order to empty the storage.



Cleaning the multi cyclone should be done once per month. On the sides of the case, there are two openings for the case. Remove the lid and thoroughly clean the case's interior. Be careful while you are returning the lid not to move the sealing tape. The centrifugal fan with the cleaning hole should also be cleaned.

A variable frequency drive controls the centrifugal fan. The frequency drive is controlled by the automatic controls system.

As the result of particles of flue gases, on the operating circuit of the fan a layer of soot accumulates, which can indicate a different fan sound. It is necessary to clean and rebalance the circuit IMMEDIATELY, because further use can lead to mechanical damage of the motor's bearings, operating circuit as well as the fan's case itself.

4. TKAN Integra cross-section

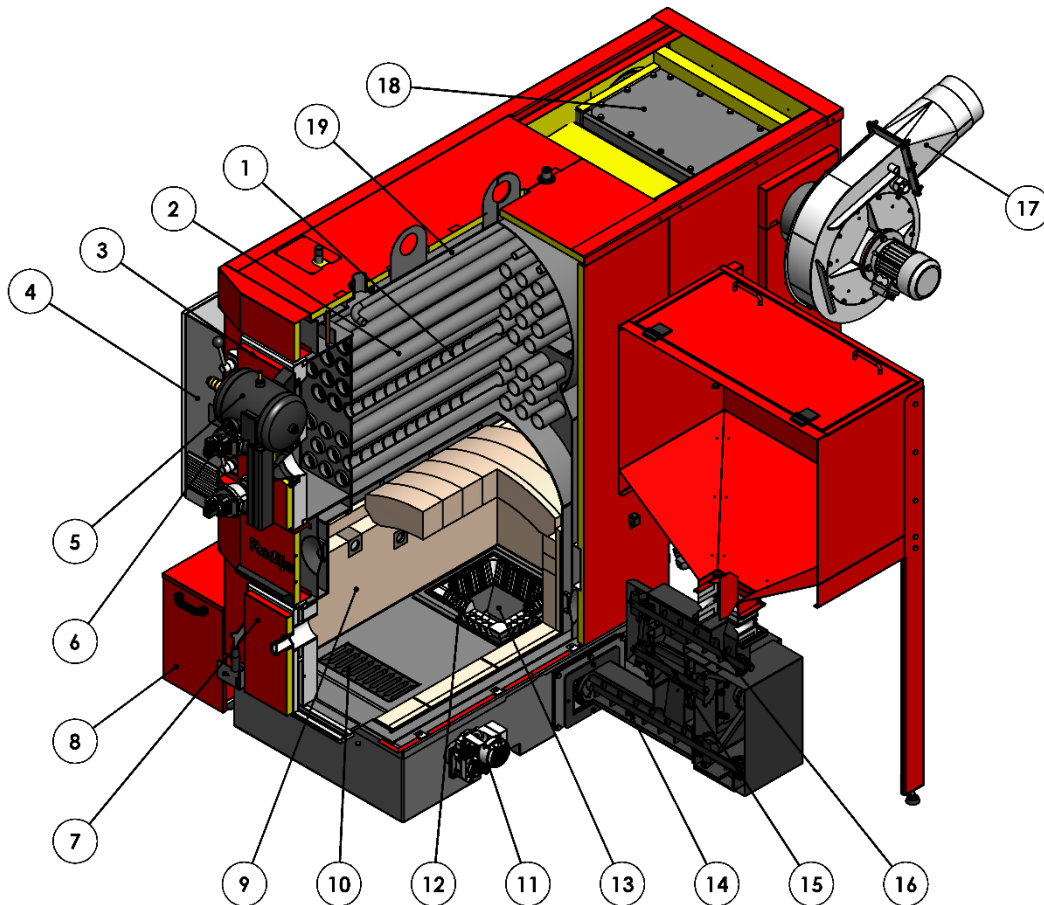

Picture 8. TKAN Integra Boiler cross section

1. Turbulators
2. Pipe exchanger
3. Door for cleaning pipe exchanger and boiler itself
4. Distribution box with automatic controls systems
5. Compressed air cartridge
6. Impulse electric valve
7. Firing and ignition door
8. Ash dump
9. Furnace lining
10. Coils for automatic ash ejection from furnace
11. Motor for initiating spiral for automatic cleaning of furnace
12. Cast iron parts
13. Boiler 's furnace
14. Lower axle of worm feeder
15. Cellular doser (valve)
16. Upper axle of worm feeder
17. Centrifugal fan of multi cyclone
18. Multi cyclone
19. Thermal safety exchanger

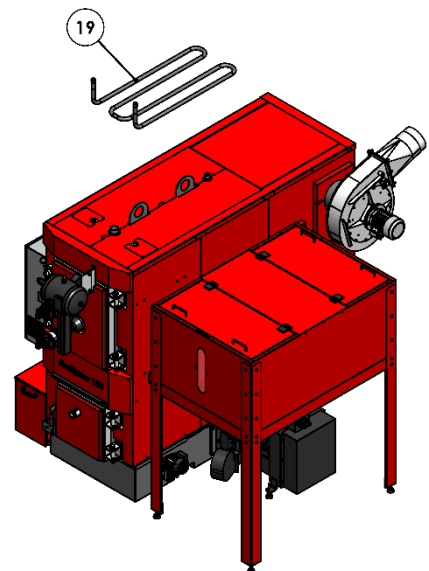

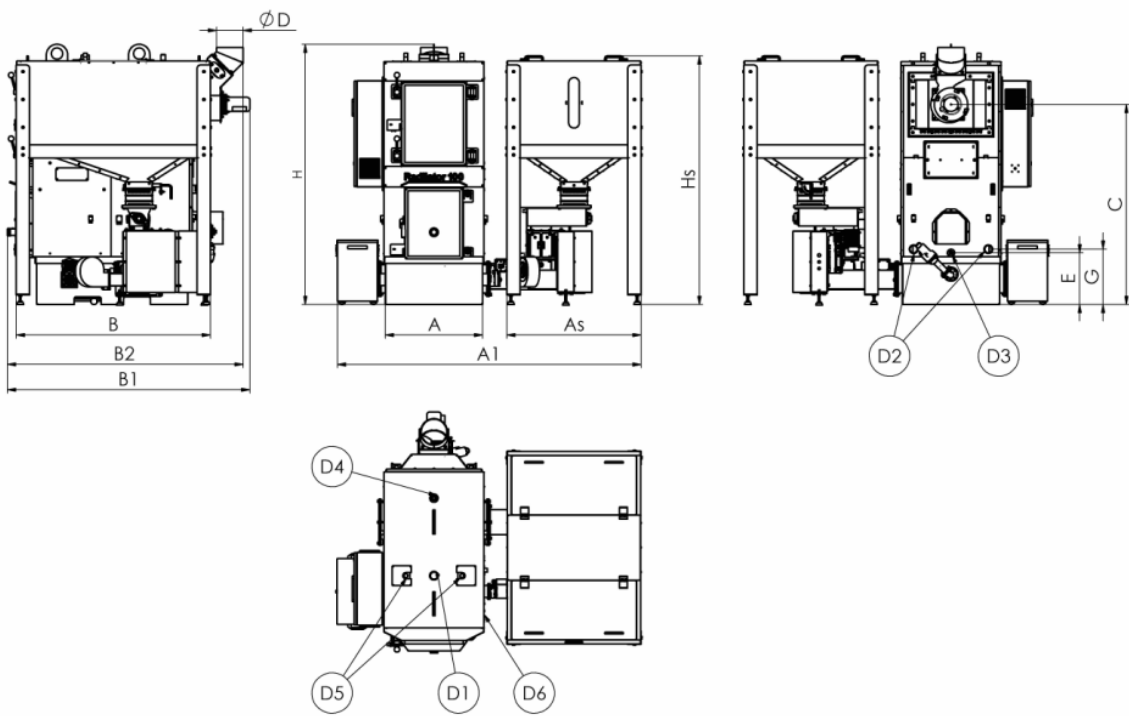

Picture 9. The design with dimensions and connection ports for TKAN 80 Integra i TKAN 100 Integra

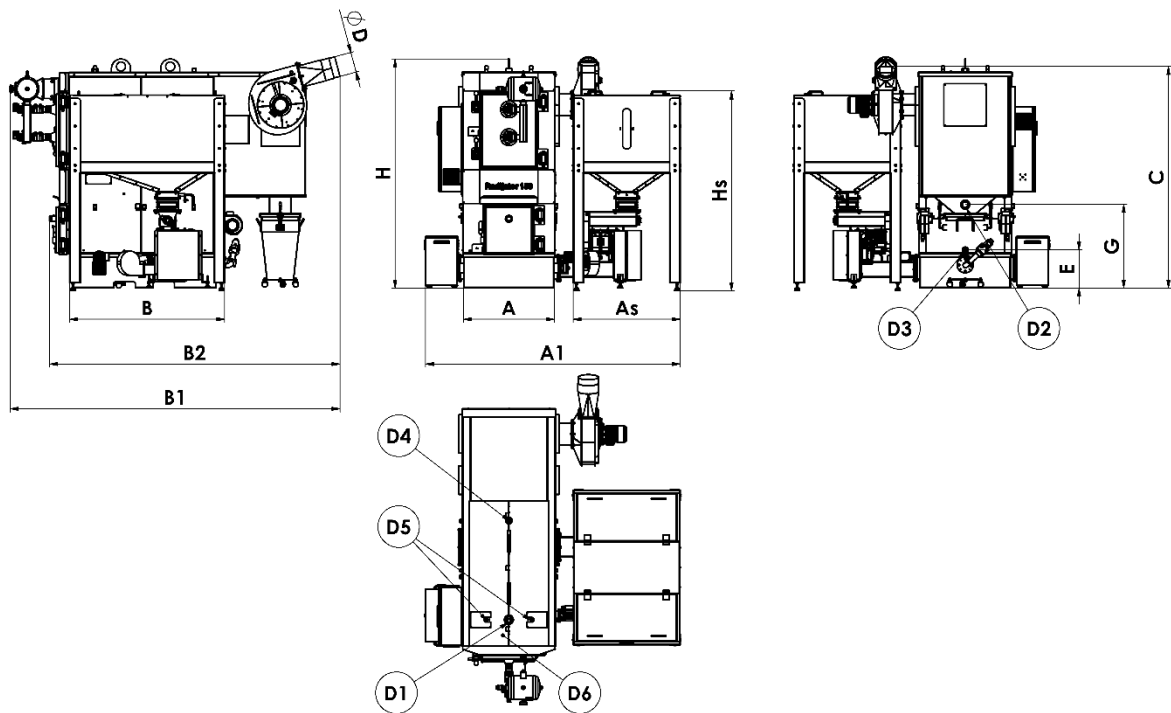

Picture 10. The design with dimensions and connection ports for TKAN 150 Integra

Ports/connections:

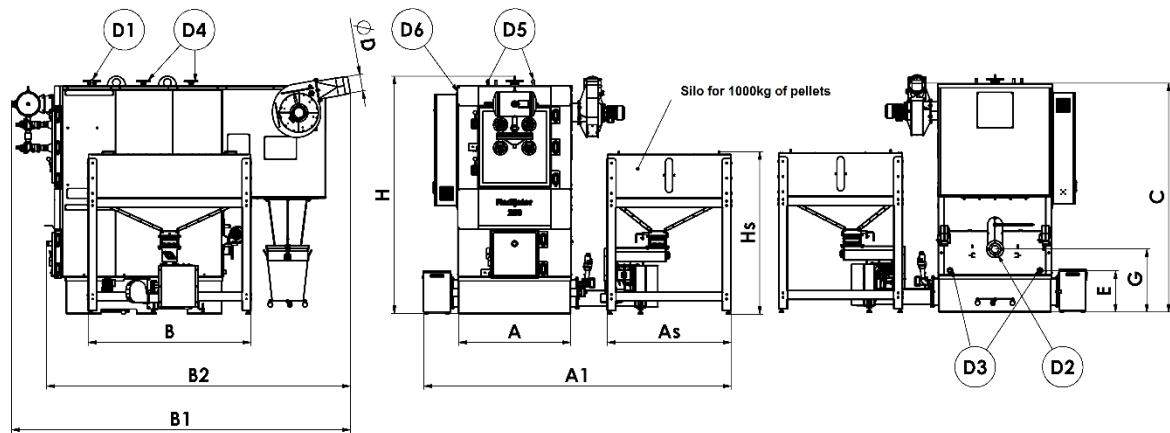

Picture 11. The design with dimensions and connection ports for TKAN 200 Integra, TKAN 250 Integra i TKAN 300 Integra

- D1 - Connection for hot water from boiler
- D2 - Connection for cold water of boiler
- D3 - Connection for filling and emptying boiler
- D4 - Connection for safety group
- D5 - Connection for thermal valve insurance swelling
- D6 - Connection for probe of thermal valva insurance swelling

In the dimensions drawing for TKAN 200 Integra, TKAN 250 Integra, and TKAN 300 Integra, a silo that can take 1000 kilograms of pellets is shown, and in the dimensions table, values for that particular one are given. If a buyer decides to buy some other silo variant, it is necessary to contact *Radijator inzenjering* to get information for that silo's size.

5. Table with dimensions

Boiler type		TKAN 80 Integra	TKAN 100 Integra	TKAN 150 Integra	TKAN 200 Integra	TKAN 250 Integra	TKAN 300 Integra		
Power	kW	80	100	150	200	250	300		
Working pressure	kPa	300	300	300	300	300	300		
Test pressure	kPa	450	450	450	450	450	450		
Volume of water in the boiler	L-cca	368	460	690	920	1150	1380		
Boiler weight	kg	1191	1415	2288	3240	4140	4440		
Silo weight	kg	100	165	165	225	225	225		
DIMENSIONS	A	mm	730	730	850	1005	1260	1260	
	A1		1788	2276	2394	2942	3455	3455	
	As		606	1006	1006	1394	1394	1394	
	B		1020	1456	1456	1830	1830	1830	
	B1		1655	1817	3099	3386	3809	3809	
	B2		1595	1767	2729	2988	3414	3414	
	C		1507	1507	2080	2515	2567	2567	
	ØD		180	200	190	190	190	190	
	E		390	390	359	465	467	467	
	G		417	417	784	675	707	707	
	H		1960	1960	2151	2547	2663	2663	
	Hs		1736	1872	1872	1822	1822	1822	
	D1		col	2"	2"	2"	DN80 NP6	DN80 NP6	DN80 NP6
	D2			2"	2"	2"	DN80 NP6	DN80 NP6	DN80 NP6
	D3			1/2"	1/2"	1/2"	DN40 NP16	DN40 NP16	DN40 NP16
	D4			3/4"	3/4"	3/4"	DN40 NP16	DN40 NP16	DN40 NP16
D5	1/2"	1/2"		1/2"	1"	1"	1"		
D6	1/2"	1/2"		1/2"	1/2"	1/2"	1/2"		
Mass flow (kg/h)		313	468	878	1116	1353	1461		

Tabel 3. Table with dimensions

6. Hydraulic diagram

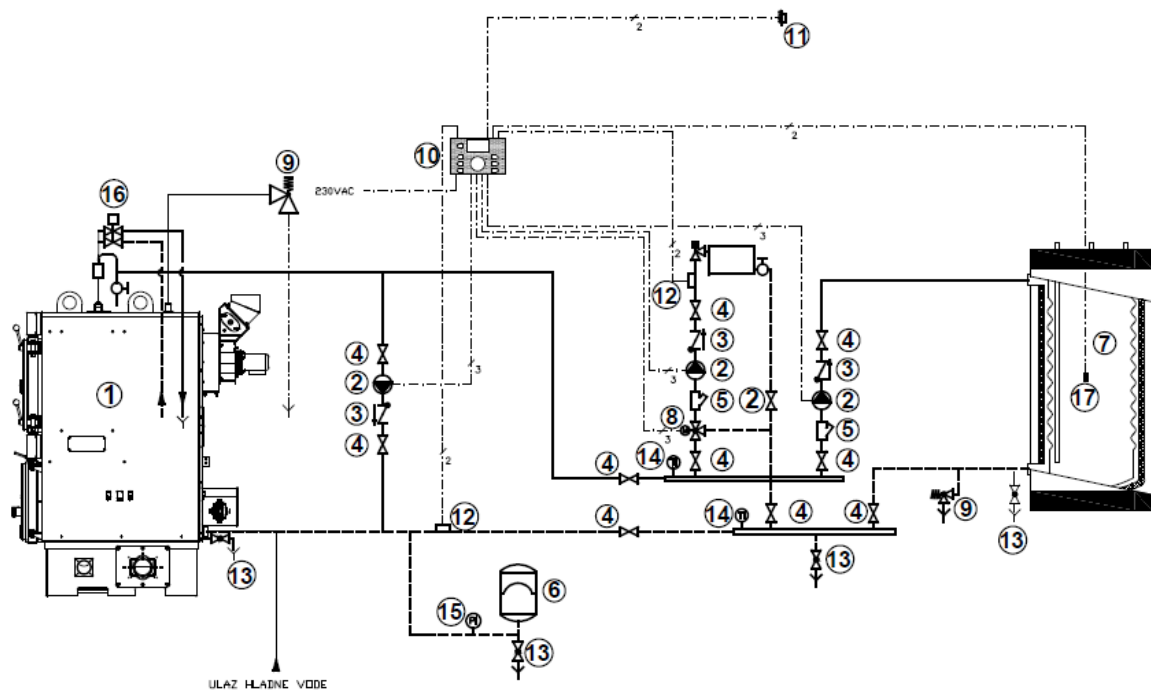

Picture 12. Hydraulic diagram of TKAN 80 Integra

1. Hotwater boiler on pellets
2. Circulation pump
3. Non-return valve
4. Shut-off valve
5. Dirt sifter
6. Closed expansion vessel
7. Hot sanitary water boiler
8. Three way mixing valve
9. Safety valve
10. Control unit – regulator
11. External temperature sensor
12. Pipe temperature sensor
13. Tap for filling and emptying
14. Thermometer
15. Manometer
16. Thermal safety valve
17. Hot water boiler sensor

7. Explanation on how to use TKAN automatic controls



The first initiation of the boiler is performed by the technician certified by Radiator inzenjering. Training for the user of the boiler is mandatory.

Accordingly, that person is licensed to report the initiation time of the boiler and its condition at that particular time to the service department while keeping a copy of the initiation report. A warranty and user's manual are given to the buyer. One copy of the warranty is sent to the manufacturer.

If the warranty isn't followed, it isn't valid.

Only boilers initiated by the licensed technician are subjected to a complete two-year warranty.

The following text is intended for the user of the boiler, as a reminder to be able to initiate the boiler by himself or herself in case of shutting down the boiler (e.g. cleaning)..



Parameters related to the operation of the boiler available to the user are located on the display. Other parameters located in the so-called hidden menu shouldn't be changed without the consent of the technician who initiated the boiler or the factory itself.

7.1 Automatic controls display

The following images show the system of operation of the touch screen as well as how you can move through the structure of the screen and make adjustments.

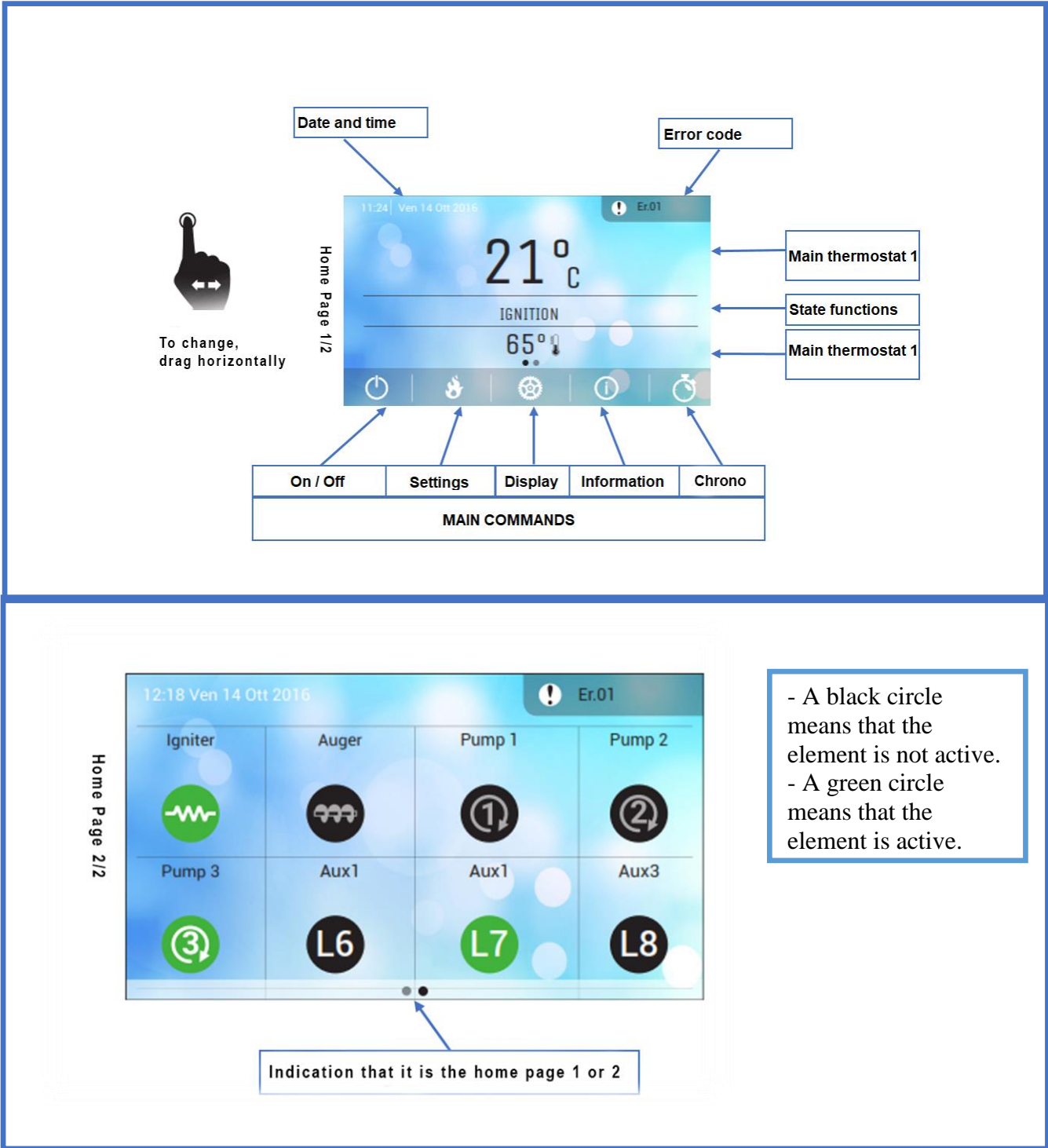

Picture 13. Display of home pages 1 and 2

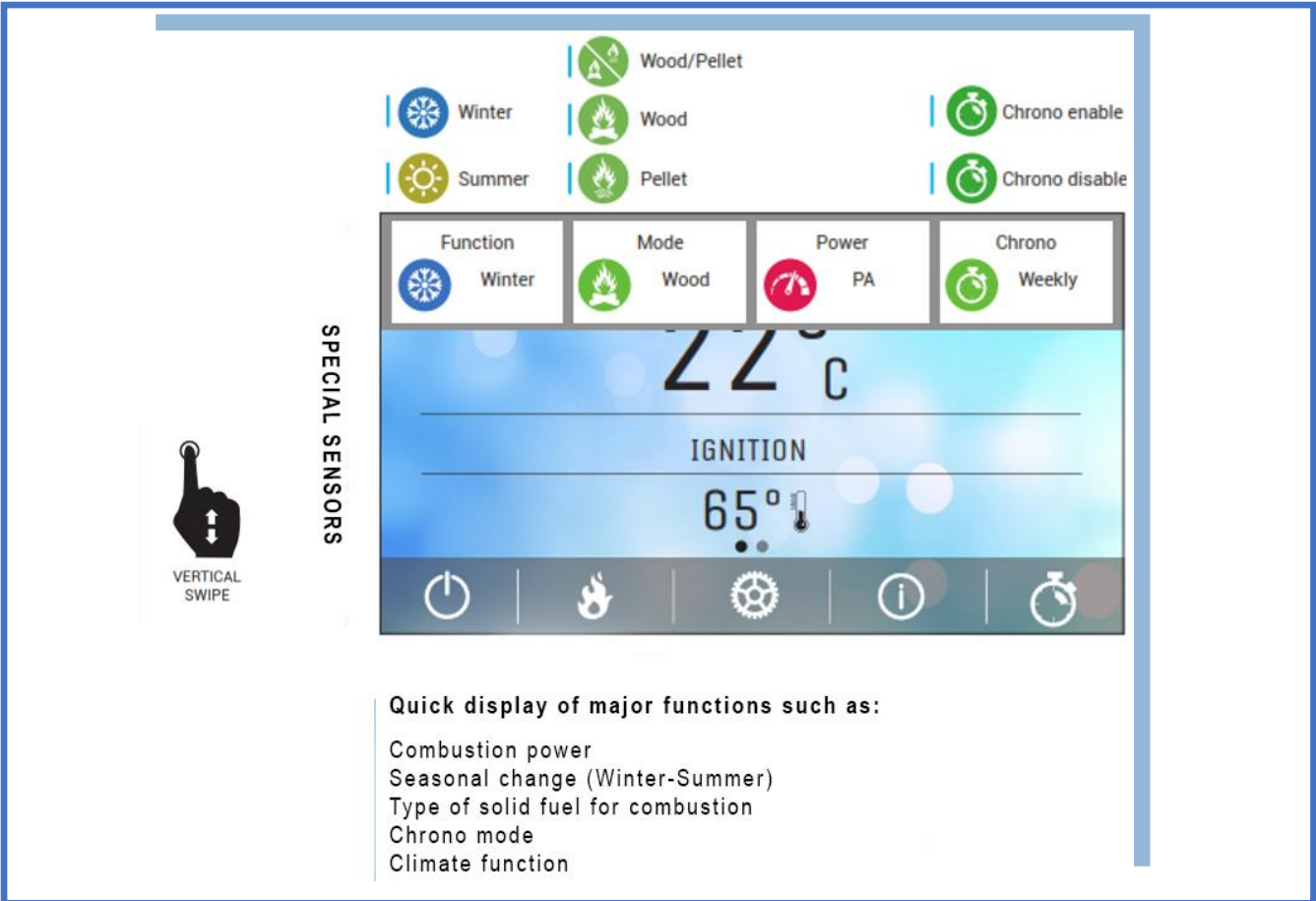

Picture 14. Quick access to some system functions



Picture 15. System operating without error

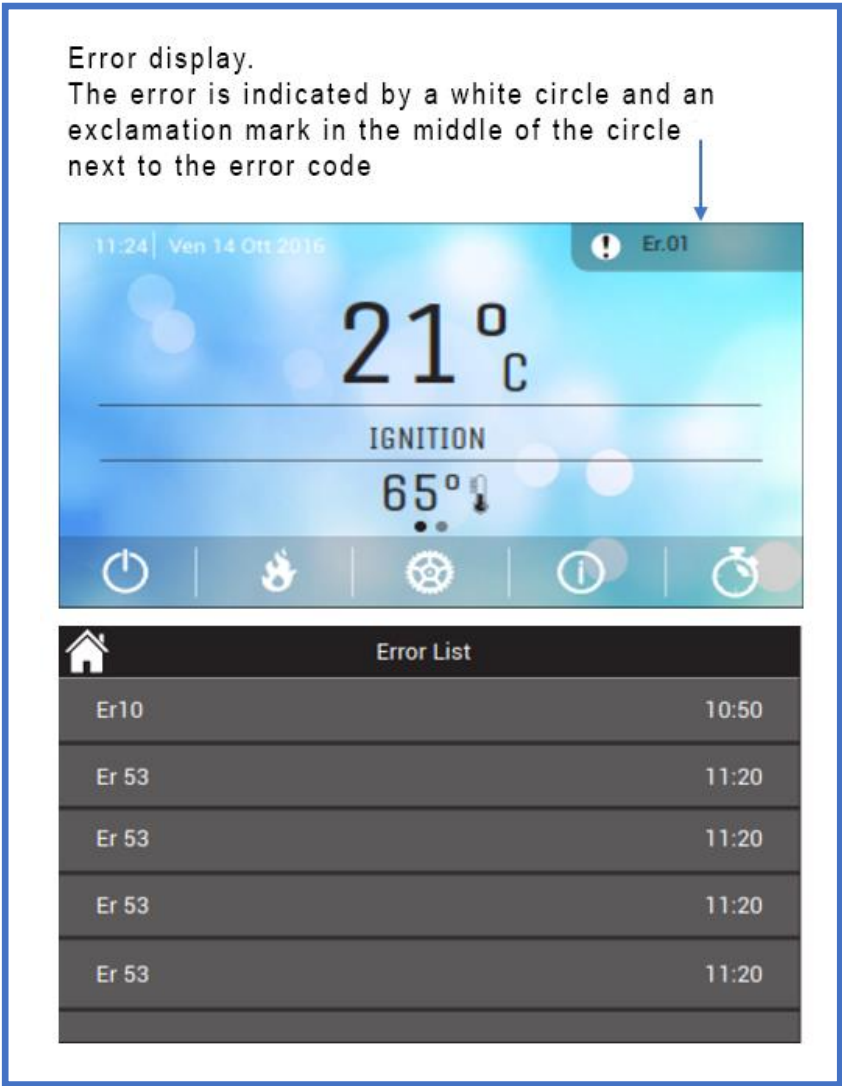

Picture 16. How error screen looks and list of errors



Picture 17. Display of main menu and submenus

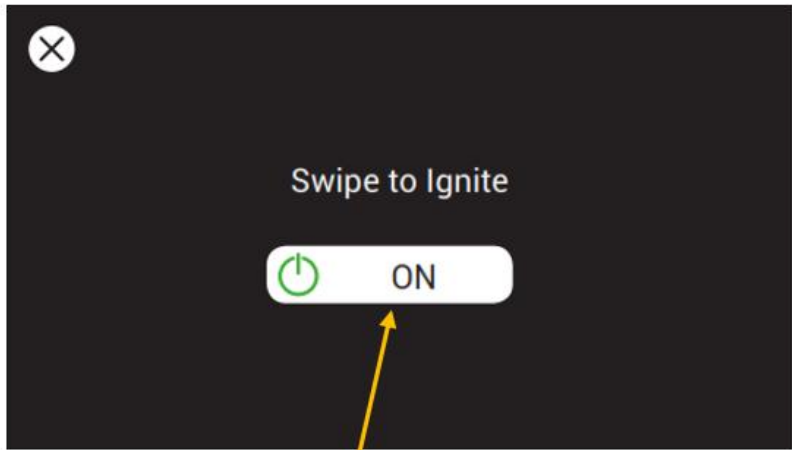

Screen used for:
Turn on the system: On
Turn off the system: Off
Alarm reset

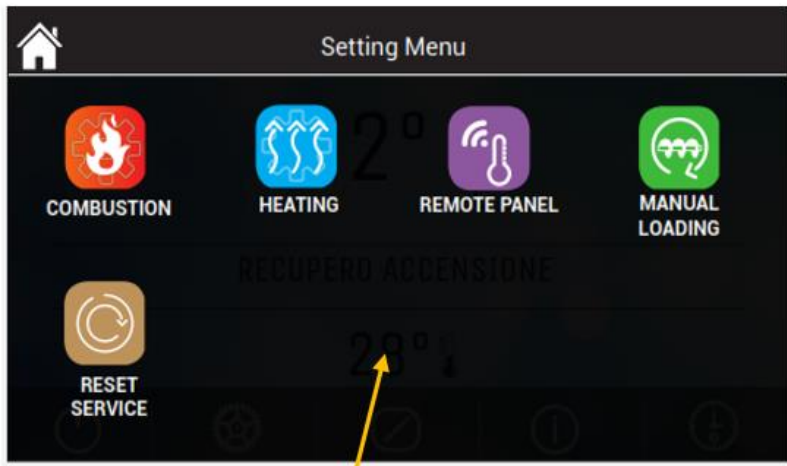

On this screen you can see all the variables for the proper functioning of the heating system

Picture 18. Display screen functions

CHRONO MODE

To change the chrono program, press the CHRONO icon on the Home screen.

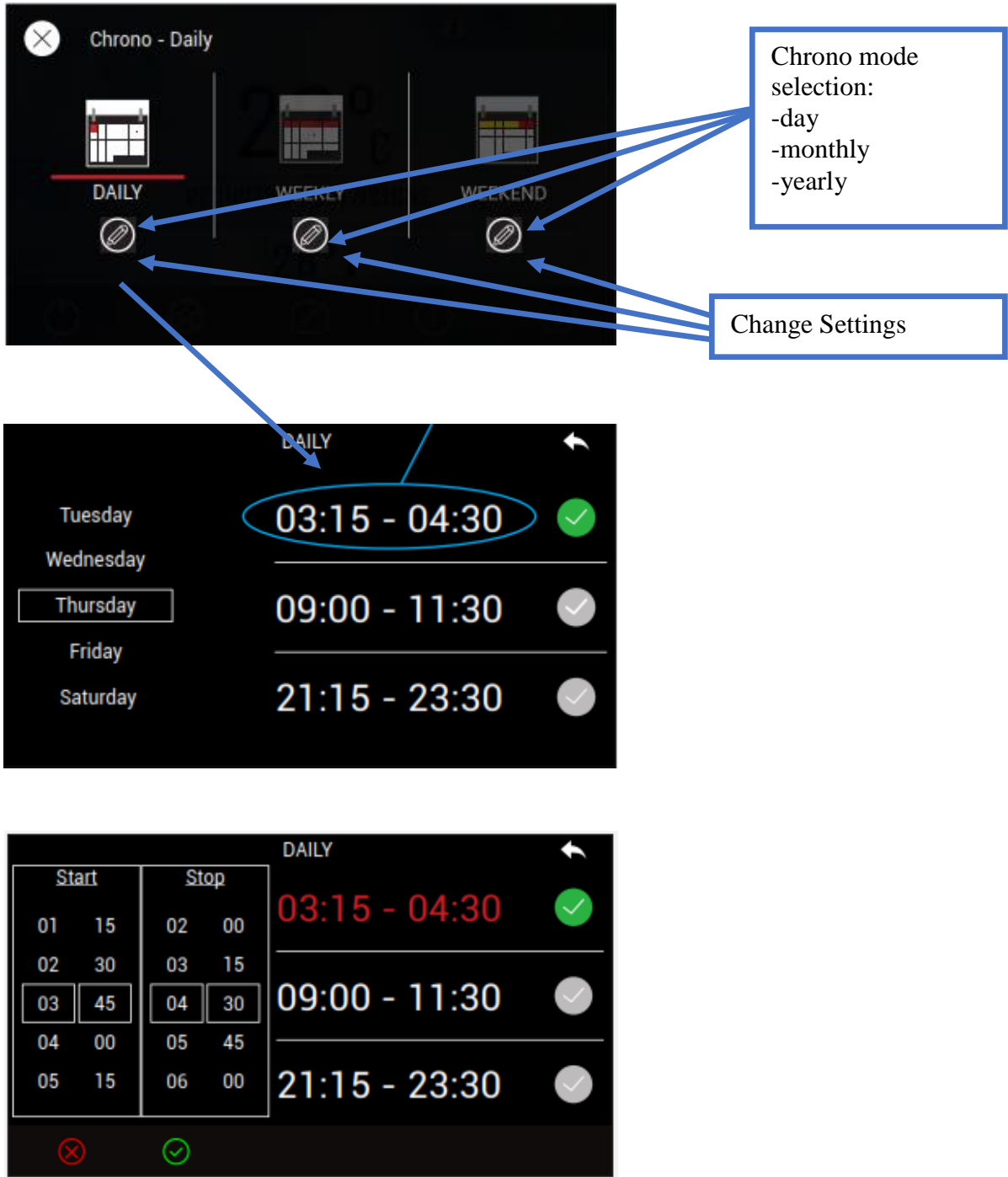

The interface shows three chrono mode options: DAILY, WEEKLY, and WEEKEND. Each option has a corresponding edit icon. A callout box points to these icons with the text: "Chrono mode selection: -day -monthly -yearly".

The DAILY mode settings screen shows a list of days with their respective time ranges and status:

- Tuesday: 03:15 - 04:30 (checked)
- Wednesday: (empty)
- Thursday: 09:00 - 11:30 (checked)
- Friday: (empty)
- Saturday: 21:15 - 23:30 (checked)

The detailed DAILY settings screen shows a table for time selection:

Start		Stop	
01	15	02	00
02	30	03	15
03	45	04	30
04	00	05	45
05	15	06	00

Below the table, the time range 03:15 - 04:30 is displayed in red, with a checkmark icon to its right. At the bottom, there are red 'X' and green checkmark icons.

A callout box labeled "Change Settings" points to the edit icons in the mode selection screen.

Picture 19. Chrono mode

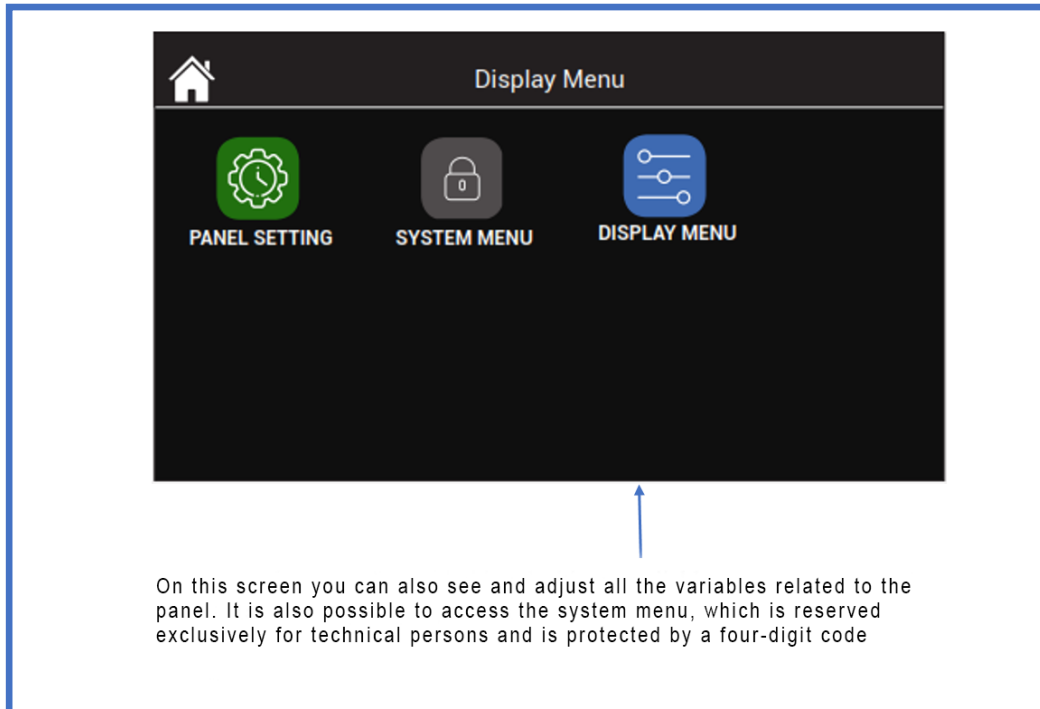

Picture 20. Menu for setting the display properties

DISPLAY MENU SETTINGS



Language selection menu



Brightness



Minimum brightness: the function allows you to select the minimum brightness level that the device will automatically adjust after 30s of inactivity



Standby display: if enabled, this function will put the screen in standby mode after 1min of inactivity



"Control panel address": password protected and used for advanced settings



Control panel reset: a function that allows the control panel to be reset



Sound: This function allows the user to turn on / off the sounds broadcast from the control panel



System Error Clear Menu: This feature is password protected (same as in the technical menu) allowing the user to clear the list of errors recorded by the control panel. The memory is 64 records.

Nodes list: the menu allows you to see all devices connected to Modbus, with firmware and revision information

Wallpaper: wallpaper selection menu. Eight wallpapers are available.

Control panel info: software version and revisions.

Error messages and the representation of important sizes

- Er01 – Safety thermostat 1 is activated (this can appear even when the boiler is off)
- Er02 - Safety thermostat 2 is activated (this can appear even when the boiler is off)
- Er03 – Shutting down due to the low temperature of flue gases
- Er04 - Shutting down due to water overheating
- Er05 – Shutting down due to extremely high temperatures of flue gases
- Er06 – The signal of pellets temperature sensor stopped working
- Er07 – The error of the encoder. There is no signal from the encoder.
- Er08 – The encoder is signaling a wrong rotation speed.
- Er09 – Low water pressure.
- Er10 – High water pressure.
- Er11 – The error signaling real-time clock problem in the automatic controls system
- Er12 – Shutting down due to a failed ignition
- Er14 – Pressure sensor read an above-threshold value (appears only when at least one of the fans is on)
- Er15 - Shutting down due to the power outage longer than 50 min
- Er16 – RS 485 Communication error
- Er18 – Pellets tank is empty
- Er20 – **Grate** sensor error (closed contact when the system is in Pellets mode)
- Er23 – Sanitary water sensor
- Er25 – Cleaning engine malfunctioned (Cleaning Engine)
- Er34 – Pressure dropped below the minimally allowed value limit
- Er35 – Pressure is above the maximally allowed value limit

Miscellaneous messages

- Sensor** The sensor shows the temperature sensor status (one or more, depending on how many are installed). A message was shown during the checking phase and shows whether the value shown by that probe is minimum or maximum (depending on the type of probe). It is checking whether the probe is open/detached or loosely connected. When the probe is open, it shows the minimum temperature from that range. When the probe is loosely attached, it shows the maximum temperature from that range.

- Service** Service Message saying the boiler worked a certain number of hours, defined in advance by the parameter
- T66.** Call a maintenance person..
- Cleaning** Cleaning Message saying the boiler worked a certain number of hours, defined advance by the parameter
- T67.** The boiler needs to be cleaned..
- Block** Message appears in phases after the sub-phase
- Preload (Ignition)** if the boiler was not shut down manually
- Door** Door is open
- Link Error** The communication between lambda panel and keyboard/screen is locked.
- Transfer** Loading new parameters failed. Try again.
- Failed** Failed.

7.2. Starting the operation of the biomass boiler

- Boiler connected to the hydraulic system.
- Drill a 4 mm diameter hole in the upper side of the flue in a zone very close to the boiler flue exit. * Only for TKAN 80 Integra and TKAN 100 Integra
- Make sure that the pellet transport mechanism is firmly supported on the floor, that the fan flap is maximally open, in cases where the fan is with a flap.
- The position of the safety air damper guides is shown in the figure. Position is important in the nominal operation of the boiler.



Picture 21. Fan valve position

** only for TKAN 80 Integra and TKAN 100 Integra*

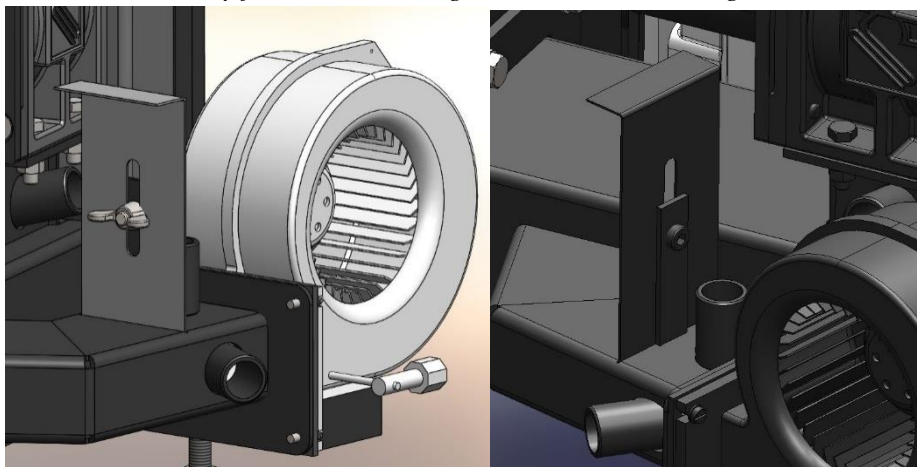

Picture 22. Valve guide position during nominal operation

- TKAN Integra 80 i 100: hole length 51mm
- TKAN Integra 150: the length of the opening is maximum
- TKAN Integra 200: the length of the opening is maximum
- TKAN Integra 250: the length of the hole is 45mm
- TKAN Integra 300: the length of the hole is 45mm

- Bring the power supply to the main distribution cabinet on the boiler. Place the main comb disconnector in position 1.
- Pour the pellets into the silo and close it.

- At this stage, it is necessary to insert the pellet into the combustion chamber by the operation of the pellet feeding system. In this way, we achieve a continuously distributed pellet from the combustion chamber to the silo. The pellet mechanism can only be started during the operation phase when the display shows "OFF" (Pic. 17).

Loading the chamber with pellets, with the so-called manual command, do it to the top of the parts made of gray cast iron, as shown in Picture 23.



Picture 23. Pellet level display

- Now that we have the pellets in the combustion chamber and when it is in the zone of the ignition heater, we can start the boiler.
- The start is performed as follows:

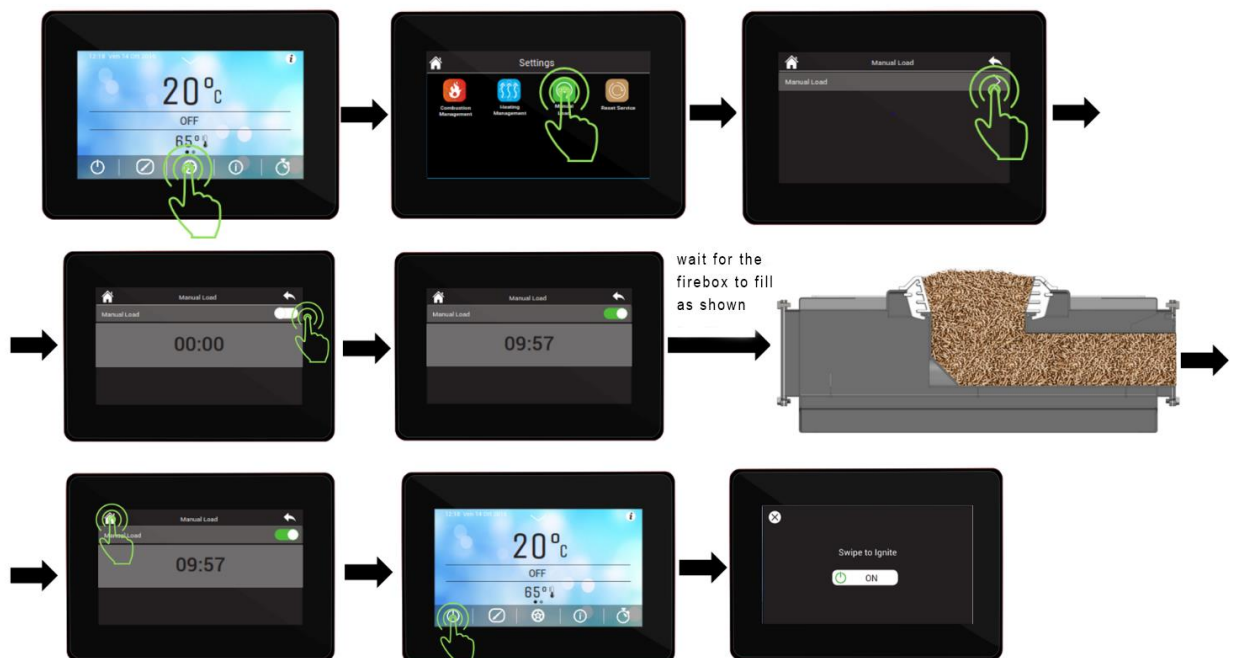

Picture 24. Procedure for manual dosing of pellets, possible only in OFF mode

- When the boiler starts igniting, Check Up appears on the display and, in these couple seconds, only the fan works. During this phase, the automatic controls system is checking if all devices required for operation are actually connected.

- The next step is when **Ignition** appears on the display. This marks the ignition phase. Then, except for the fan, the ignition heater starts which can be checked on the automatic controls system. Homepage 2/2 picture. In the ignition phase, according to factory settings, the pellets transport system does not initiate.
It is likely that, while the automatic controls system is working, the automatic dosage by adjusting parameter T03 in the hidden menu will be used instead of the manual pre-dosage. The automatic pre-dosage is not recommended because the amount of time necessary to load the furnace (as shown in picture 16) varies and depends on multiple factors including the chimney construction itself even weather conditions (air pressure).
- the boiler is in the ignition phase until flue gases do not exceed the temperature determined by parameter Th09. According to factory settings, this temperature is 50°. First, smoke appears and within 7 to 10 minutes flame appears as well.
- Once flue gases exceed the ignition temperature limit, a Stabilization message appears on the display. This means that the boiler is in the flame stabilization phase, that is, the automatic controls system is measuring if flue gases have sufficient increase for a certain time period. The fan operates according to the stabilization phase parameter, and the furnace is recharged with pellets also according to the parameters of the worm in the stabilization phase. Once this factor is also met, the boiler enters the running mode **RUN MODE**.
- The boiler is in the running mode while RUN MODE is shown on the display except for the current water temperature in the boiler. Wait for 20 to 30 minutes and see if pellets are burning on top of the combustion chamber. In this period, also monitor the temperature of flue gases. The temperature of flue gases and other vital parameters can also be read at any time by pressing the button on the main display.
- To the automatic controls system, a room thermostat can be connected if a user requests it. In this case, it is important to set the room temperature which is the main parameter for the boiler to run, and for the water temperature in the boiler (70°C). Once a room thermostat is activated, the boiler primarily aims to reach the room temperature, however, it is limited by the set temperature of the water inside. The boiler will likely stop running before reaching the set temperature of a room thermostat, and, in this case, the set temperature of the water in the boiler should be increased to, for example, 70°C.
- The combustion of pellets, regardless of the boiler's operating power, needs to be set so that is on top of the combustion space. This is achieved by setting the dosage of pellets and the amount of air. Should the level of flame start decreasing, it is necessary to prolong the dosage time or to reduce the amount of air. If we want to reduce heating power, it is necessary to reduce the amount of air. If the level of flame is increasing, we can reduce the firing time or increase the amount of air. To determine parameters precisely, it is necessary to follow the operation process for at least one hour.

NOTICE: Always adhere to the nominal or peak power of pellets combustion, that is when pellets are burning on top of the burner. In this case, decreasing thermal power is done by decreasing the set temperature of water in the boiler or set temperature of the room thermostat.

A place where the pellets “jump” during combustion



Picture 25. The representation of the perfect combustion of pellets



Warning: It is mandatory to analyze flue gases upon installing the boiler. Measure percentage of oxygen (O₂).

7.3 A short guide to using automation

7.3.1. Filling the firebox with pellets, preparing for ignition and starting the pellet fire

The procedure is shown in the picture below:

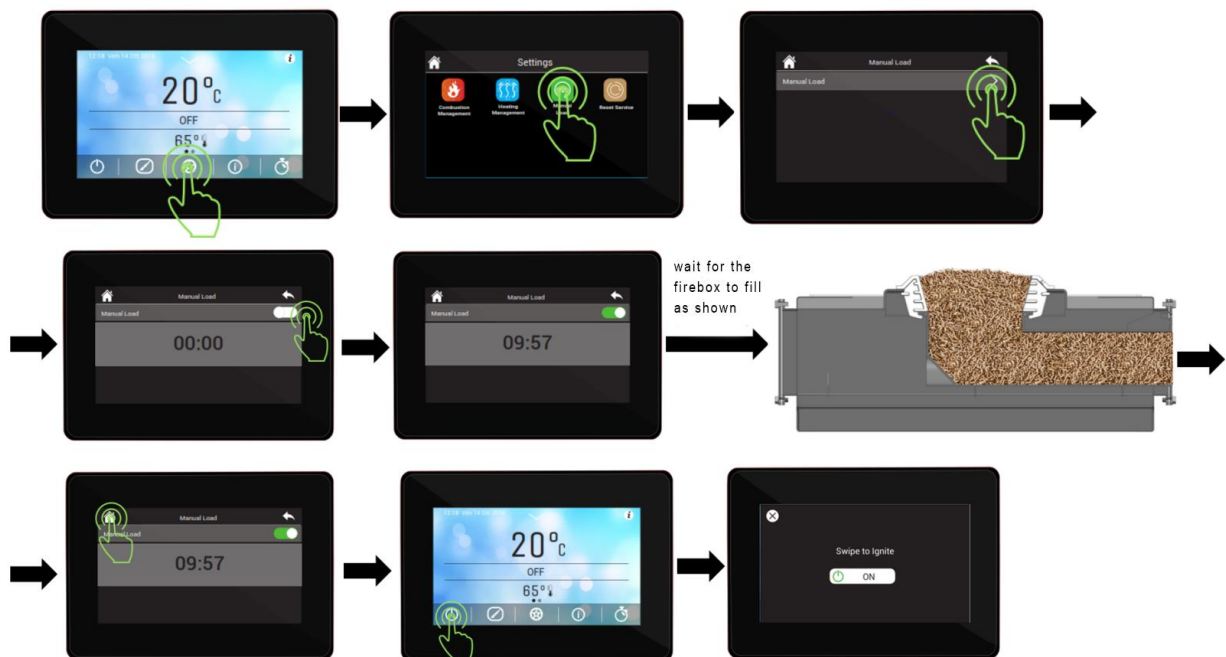

Picture 26. Starting the boiler

7.3.2. Changing the dosing time of the transporter in the operating mode

The menu for modifying this running time and combustion speed of the doser. 10 calibration levels are available, 5 for increasing, and 5 for decreasing, the 0 value corresponds to factory settings. Changes in this menu directly impact the power of recipe combustion in the Run Mode and Modulation. For each settings' step, value increases or decreases for the percentual value P15 that can be adjusted in the hidden menu. This menu is visible only if P11 differs from 1.

Example: P15=10%, Step=-1

Default values	CO3=2,0	CO4=3,0	CO5=4,0	CO6=5,0	CO7=6,0	C11=1,0
Calibrated values	CO3=1,8	CO4=2,7	CO5=3,6	CO6=4,5	CO7=5,4	C11=0,9

Table 4. Changing the dosing time of the conveyor in the operating mode

The calculated values belong to the range defined by parameters P27 and P05.



Picture 27. Changing the dosing time of the screw transporter

7.3.3. Changing the power of the fan in the running mode

The system has 10 calibration systems. Changes in this mode impact the current recipe and operational power in the Run Mode and Modulation. For each settings' step, value increases or decreases for the percentual value P16 that can be adjusted in the hidden menu. This menu is visible only if P11 differs from 1. How to change is displayed in the picture.

Example: P16=5%, Step=+3

Default values	UO3=1000	UO4=1200	UO5=1400	UO6=1600	UO7=1800	U11=900
Calibrated values	UO3=1150	UO4=1380	UO5=1610	UO6=1840	UO7=2070	U11=1030

Table 5. Changing the fan power in operating mode



Picture 28. Changing the fan power in operating mode

7.3.4. Changing the set water temperature in the boiler

The menú for changing the desired temperature. It is limited by the minimum and maximum values. To change, follow the next steps.



Picture 29. Changing the set water temperature in the boiler

7.3.5. How to read the flue gas temperature

If you want to read the flue gas temperature, follow the steps below.

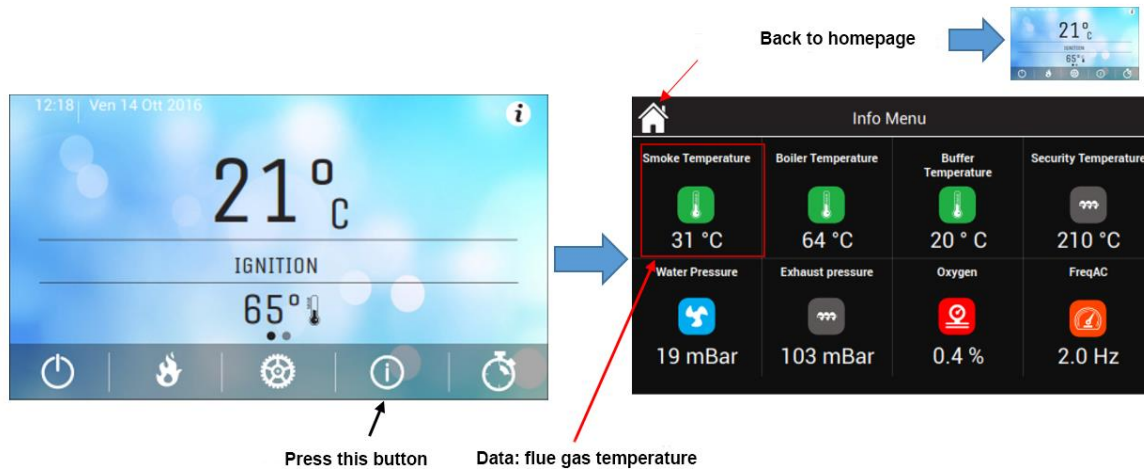

Picture 30. Flue gas temperature reading

7.4. Errors while starting the boiler

All possible errors in the initial operation phase, that is during ignition can be split into three big groups:

- **Group I** Errors during ignition relating to the situation without sparks, smoke, or any flame for more than 20 minutes from the moment of starting the ignition heater.
- **Group II** Errors during ignition relating to the situation in which flame appeared but the boiler shut itself down after a certain period (a few minutes).
- **Group III** The boiler successfully ignited and was working for a few hours. Reached the set temperature and, for a longer time, there is no need to turn on neither the dosing system nor the fan (this situation is mostly overnight). Right after, the temperature is dropping and the user wants a higher temperature (mostly in the morning), and the boiler receives a signal to enter the ignition phase, but there is no flame.

Group I

Possible **cause 1**.

- **PROBLEM 1** – The flap of the fan for primary air is closed. The fan is located on the doser.
- How to solve **PROBLEM 1** – Open the flap completely.

Possible **cause 2**.

- **PROBLEM 2** – The hose connecting air channels from the fan to the heater is not properly set.
- How to solve **PROBLEM 2** – Affix the air hose both to the case of the heater and to the air channel pipe.

Possible cause 3

- **PROBLEM 3** – Space deep in the furnace where pellets are combusted is full of uncombusted remnants, that is cinders, therefore, there is no contact between pellets and hot air.
- How to solve **PROBLEM 3** – Clean the depth of the furnace, primarily larger cinders mechanically and smaller cinders can be vacuumed.

Possible cause 4

- **PROBLEM 4** – Pellets used are highly moist.
- How to solve **PROBLEM 4** – Try drier pellets.

Possible cause 5

- **PROBLEM 5** – Mains voltage to which the boiler is connected is significantly lower than 220-230V, therefore the power of the heater is lesser.
- How to solve **PROBLEM 5** – Priključiti mrežni ispravljač napona ili potpaliti ručno.

Possible cause 6

- **PROBLEM 6** – The boiler is switched from automatic to manual operation mode. If during the entire ignition phase, the heater light isn't on, then the boiler is certainly in manual mode.
- How to solve **PROBLEM 6** – Refill pellets.

Possible cause 7

- **PROBLEM 7** – The boiler is switched from automatic to manual operation mode. If during the entire ignition phase, the heater light isn't on, then the boiler is certainly in manual mode.
- How to solve **PROBLEM 7** – Switch the boiler to the automatic ignition mode.

Possible cause 8

- **PROBLEM 8** – The electric heater malfunctioned. Disconnect the boiler from mains voltage and measure the electrical resistance of connection cables of the electric heater.
- How to solve **PROBLEM 8** – Replace the electric heater.

Group II

Possible cause 1.

- **PROBLEM 1** – Fan speed in the ignition phase. Fan speed for primary air in this phase is determined by parameters Uc00 and Uc01. If the speed is drastically changed in comparison to the factory set one, it is not good to either drastically decrease or increase it. In case the fan, while igniting, is weak, the temperature of flue gases doesn't increase and if it is too powerful, it is possible to rapidly consume pellets in the chamber which leads to decreasing temperature of flue gases while igniting.
- How to solve **PROBLEM 1** – Set values of parameters Uc00 and Uc01 to the factory values or near-factory values.

Possible cause 2

- **PROBLEM 2** – Fan speed in the flame stabilization phase. The boiler enters the ignition phase, smoke appears, the display indicates Stb which means it's in the flame stabilization phase but after that, the boiler shuts down. The most common cause of this is a too weak fan in the stabilization phase which is determined by parameter Uc02.
- How to solve **PROBLEM 2** – Increase fan speed using parameter Uc02.

Possible cause 3

- **PROBLEM 3** – Too big or too small amount of pellets in the stabilization phase. If there are not much or too many pellets while the display is indicating Stb, that is stabilization, flame congestion can occur and the boiler may return to the shutdown phase. The amount of pellets in the stabilization phase is regulated by parameter C04.
- How to solve **PROBLEM 3** – value of parameter C04 to the factory value or near-factory.

Possible cause 4

- **PROBLEM 4** – The boiler entered the stabilization phase but still enters the shutdown phase because the temperature increase is not sufficient. Particularly stagnation, that is marginal drops of the temperature of flue gases is noticeable at the moment of refilling the furnace with pellets.
- How to solve **PROBLEM 4** – Raise the flue gas temperature for the system to enter RUN MODE, which is a parameter of Th09. In this way, the new pellet that enters the combustion chamber has a harder time lowering the temp of flue gases because the flame is stronger due to the fact that it was given more time until the moment of replenishment. This problem most often occurs when the chimneys are weak or the draft of the chimney is weak for some other reason.

Possible cause 5

- **PROBLEM 5**– The boiler entered the stabilization phase but after some time enters the shutdown sequence.
- How to solve **PROBLEM 5** – The ash dump was forgotten to be put back into the boiler or to be closed firmly.

Group III

When the boiler reaches the set temperature of the water inside or the temperature of the air in the room with the room thermostat, it enters the standby phase, more precisely the flame maintaining phase or the original standby phase. The best example of this way of working is the night mode. The basic goal of this phase is to maintain phase, more precisely embers in the furnace during the multi-hour standby. That is achieved by initiating periodically both the pellets feeder and fan at certain time intervals.

The moment the boiler reaches the set temperature, it enters the flame maintenance phase. This phase has two subphases pause and work. In the pause phase, the dozer is switched off and only the chimney fan or cyclone at UA14 speed works. In the work phase, a small combustion starts in order to maintain the grill, the parameters are UA12, US12, UC12.

Possible operating errors related to the flame maintenance phase:

- The boiler, apart from running the flame maintaining phase, does not have enough pellets to start and run in normal mode.
- Removing the cause of this error:
 1. Reduce parameter T32, that is increase the frequency of running of the transporter and fan in the standby phase.
 2. Increase the length of a process, that is parameter T33.
- Excessive amount of uncombusted pellets while initiating the boiler.
- Removing the cause of this error:
 1. Increase parameter T32
 2. Decrease parameter T33
 3. Decrease the power of the primary combustion fan in the flame maintenance phase, parameter UA14.

8. Boiler's maintenance

TKAN boiler requires daily and periodical cleaning.

1. Daily (at least weekly) cleaning also applies to the boiler's space of grey cast iron where we, by constantly ejecting ash, enable more efficient operation of the electric heater for firing and more efficient combustion, that is larger amount of air through air channels in the grey cast iron. Also, ash starts piling up during the day on the floor, in the area around the furnace itself. According to average combustion parameters, 100kg of pellets produce 1kg of ash, but this information significantly varies depending on the type and quality of ash.
2. Each 7 to 10 days, shutting down the boiler is recommended, cooling off a few hours, and manual or, the best, vacuuming depths of the combustion chamber. This removes even larger pieces of uncombusted pellets which can cause unpleasant sound while the boiler is working and decrease the lifespan of the screw spiral which pushes pellets into the combustion space.
3. Once a month, it is necessary to open the upper door for cleaning as well, remove turbulators and remove layers of tar and soot from pipes of the exchanger. Everything removed at that point is picked on the upper surface of the furnace roof or in the smokebox. Too much ash in pipes of the exchanger decreases utilization of the boiler and leads to excessive temperatures in the furnace which can cause deformations to it, that is to the lower door.
4. Cleaning the multi cyclone should be done once a month. On the case's sides, there are two cleaning holes. Remove the lid and thoroughly clean inside the case. Be careful when returning the lid not to move the sealing tape. Also, clean the centrifugal fan that has a cleaning hole on the pipe.
5. Regardless of the automatic dedusting, some parts should be cleaned manually and those are:
 - a part located under pipe exchangers (can be seen when the upper door is open)
 - some pipe in the exchanger located in corners.
 - Clean periodically, at least once a month.
 - It is mandatory to, once a day, release the water from the compressor's tank by using the valve located at the bottom of the tank.
 - It is mandatory to empty the bowl in the FRL unit where condensation (water) is accumulating.
 - If unit B is installed, it is mandatory to, daily, release the water from the tank by using the valve located at the bottom of the tank.
6. Cleaning heater pipes is recommended to be done monthly, cleaning the filter of the heater in a licensed maintenance department.
7. The inspection of the turbine's validity is done yearly and balancing when needed (when a regular yearly maintenance is done), and balancing the turbine is mandatory every second year.
8. The safety valve needs to be calibrated yearly according to the law in a licensed laboratory specialized in calibrating equipment.

9. It is mandatory to, once a month, inspect the validity of the electric heater for Leister's ignition if it is necessary to clean the pipe to which it is installed.
10. Once the heating season is over, the maintenance of the boiler is mandatory.

Warning: Depending on the mode and working conditions, quality of pellets, that is biomass, listed cleaning periods may even be more frequent.

If condensation occurs in the boiler while using it, it is necessary to deal with the condensation and to coat the entire boiler from inside with basic cleaners or at least with aqueous solution of builder's lime. That way, the neutralization of acid due to condensation is done.

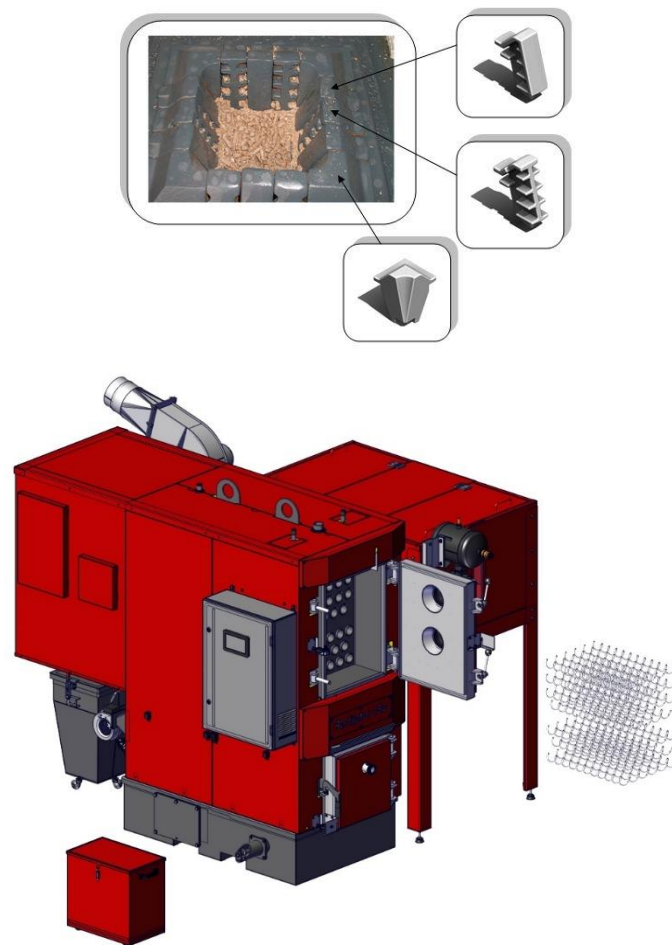

Picture 31. The representation of removing the turbulator from the TKAN boiler, disassembling cast-iron segments of the furnace, and cleaning the ash bin



This way, conserve the boiler imperatively at the end of the heating season. In that situation, close all holes on the fireplace to avoid air circulation through the fireplace because that can result in the appearance of moisture inside.



Boiler maintenance is one of the most important factors for the length of boiler life. It is especially important that in the off-season the boiler is cleaned and that the neutralization of acids is performed in the manner already described.

9. Warranty

Radijator inzenjering covers different warranty periods for various parts (as listed in the following text) only if the following warranty conditions are met:

- The boiler has to be connected according to all hydraulic diagrams from the technical instruction manual, especially pay attention to safety valves, thermal leakage protection, the mixing valve-pumps for protecting the cold end of the boiler, that is, against condensation, range of the working pressure of the boiler, range of the working temperature of the boiler, conditions of the boiler room, etc. (see **point 6**)
- The boiler has to be connected to the chimney of a regulated cross-section, characteristics, isolation, and height (see **point 3.3**). The smoke channel from the boiler to the chimney has to be done by the technical instruction manual
- The boiler also has to have listed electric connections from the technical instruction manual, especially characteristics of the room thermostat, characteristics of the mains voltage which has to be within certain limits.
- The user has to follow the listed instructions on how to use and maintain. (See **point 8**)

Warranty statement

We state:

- that the product has regulated and declared quality properties. We oblige to, on the request of the buyer if he/she timely within warranty period submits the repair request, cover all repair costs so that the product will operate according to its declared properties,
- that the product will work flawlessly within the warranty period provided that the use, operation, and installation instructions are followed,
- that we will be ready to remove all product malfunctions and have all necessary spare parts in stock within the warranty period,
- **the warranty period starts from the DAY OF PURCHASE AND LASTS 60 MONTHS OR 72 MONTHS FROM THE PRODUCTION DATE (the production date is located on the label at the back of the boiler),**
- **THE 60-MONTH WARRANTY APPLIES ONLY IF THE BOILER IS REGULARLY SERVICED BY THE RADIJATOR INZENJERING CENTRAL MAINTENANCE in the period listed for it (hereinafter). the warranty applies if the warranty paper is certified by the seller and if the purchase date is written**

and if the receipt is attached. IT IS ALSO IMPORTANT TO HAVE INITIATION WARRANT (certified by the licensed maintenance department)

1. The 1-year warranty period applies to the following parts:

- All UCFL series bearings,
- electrical heater for ignition,
- bearings of cellular safety transporter (valve),
- Fan on the cyclone (If there is damage to the turbine and the fan due to non-maintenance of the boiler, the costs are borne by the customer)

2. The 2-year warranty period applies to the following parts:

- electric gear motor,
- torque transmission chain 083,
- lower screw coil,
- primary air fan,
- secondary air fan,
- automatic control system of the boiler with safety valve,
- smoke gases probe,
- boiler water temperature probe.
- cast iron segments for combustion,
- electric connectors,
- insulation materials on doors and cleaning holes,
- parts of cellular safety transporter (valve) made of grey and modular cast iron.

3. Warranty period doesn't apply:

- unless the regular maintenance is done after each heating season,
- in case of the replacement of parts during the annual maintenance in accordance with the instructions,
- in case of malfunctions caused by the buyer because of unprofessional handling,
- in case of mechanical failures made during transport and use (solid objects),
- if the product was installed unprofessionally, contrary to the valid regulations in that aspect,
- if it is found that the hydraulic diagram was not made according to the recommendations of company Radijator inzenjering the buyer used the product outside of declared properties in normal circumstances",
- if the customer has used the product above the declared properties and under normal circumstances,
- if air containing water and oil enters the boiler exchange space RADIJATOR ENGINEERING:
 - does not recognize the warranty on the boiler and the dedusting system

- does not bear the consequences of possible contamination of the boiler or explosion of water vapor which can cause material damage and human casualties.

4. Warranty period isn't valid:

- if it is found out that malfunctions were removed by an unauthorized person or an unauthorized maintenance department,
- if some air containing water and oil enters the exchanger space,
- if during the repair the original parts were not used and installed,
- upon the expiration of the warranty period.

5. When reporting malfunctions, it is mandatory to provide the following information:

- name and type of the product,
- date of purchase,
- factory or workshop number of the fireplace,
- brief malfunction description, that is the description of a defect,
- exact address and contact number, mail.

6. Regular yearly maintenance

Regular maintenance is done at the end of each heating season from April 15th to August 31st and is charged according to the set price list of Radijator inzenjering company. The maintenance procedure, performed by technicians performing regular yearly maintenances authorized by the company, include the following operations:



NOTICE: The servicing technician is obliged to inspect all listed parts (from the list) of the dosing unit and exchanger and if it comes to the replacement of any parts the user receives the aforementioned warranty and the additional 12-month warranty for the boiler body (exchanger) as well. The warranty can be extended up to 5 years from the initiation date. The maintenance and extension can be done by the person sent by the central maintenance department of Radijator inzenjering. The warranty isn't valid to unchanged parts upon completing maintenance.

Maintenance procedure:

1. Disassembling the pellet silo from the pellet transporter;
2. Disassembling the pellet transporter from the boiler;
3. Removing both chains, sprockets and bearings from the furnace;
4. Disassembling combustion parts from the furnace and cleaning the space beneath the boiler parts for cleaning; Inspecting the condition of parts and the gap between them;
5. Cleaning the space of pipes where the lower screw spiral rotates;

6. Lubricating all bearings of upper and lower screw sxle and inspecting their functionality. The bearing musn't have aggravated rotation or have any cracks on the case. On the contrary, the bearing is replaced. If it is determined that damages on bearings was caused by certain solid object or accumulated dust, bad quality of pellets in the pellets transporter, Radijator inženjering charges the value of the bearing. If the damage of the bearing was caused by the withdrawal of flame into the pellet transporter because of improperly set parameters while using, Radijator inženjering charges the value of the bearing;
7. Removing chains from both sides of shaft of the cellular safety transporter (valve) and insprcting functionality of bearings in the valve. If the rotation of bearings is made aggravated, replace them brom both sides. If the damage of valve bearing was caused by a solid object not from the boiler itself falling in (user's mistake or pellet manufacturer's mistake). Radijator inženjering charges the value ot the bearings;
8. Inspect the sharpness of rotor's edges;
9. Remove the fle gases probe and clean it from deposits;
10. Inspection of primary and secondary fan and cyclone fan if the cyclone is in the boiler as the additional equipment;
11. Inspection of sealing of upper and lower door;
12. Inspection of boiler's exchanger maintenance;
13. Inpection of the pollination system if the pollination system is on the boiler as the additional equipment;
14. Inspecting the condition of cyclone on the boiler if the cyclone is on the boiler as the additional equipment;
15. Inspecting the condition of cleaning coils and electric motor redactor on them;
16. Inspecting the functionality of firing fan;
17. Check the condition of the heater pipes and filters and clean them
18. Check the operation of the turbine fan, and balance the turbine every other year.



RADIJATOR-Inženjering d.o.o

Živojina Lazića Solunca br.6

36000 Kraljevo

telefoni za kontakt:

036/399-140, 399-150

e-mail: radijator@radijator.rs

GARANTNI LIST / GUARANTEE LIST

Tip kotla / Boiler type

Fabrički broj / Factory

Garantni rok / Guarantee period

60 MESECI / 60 MONTHS

**Datum proizvodnje /
Date of manufacture**

**Potpis ovlašćenog lica /
Signature of Authorized**

____ pečat / stamp

Prodato u firmi / Company of Sale

Adresa / Address

Telefon /

Datum prodaje / Date of Sale

Potpis / Signature

*Potrošač ima sva prava na osnovu Zakona o zaštiti potrošača ("Sl. glasnik RS", br. erbia62/2014). Garancija ne isključuje niti utiče na prava potrošača koja proizilaze iz zakonske odgovornosti prodavca za nesaobzornost robe u ugovoru./The consumer shall exercise all rights under the Consumer Protection Law ("OJ of RS" No 62/2014). The guarantee does not exclude nor affect the consumer's rights derived from the legal liability of the seller for any lack of conformity of the goods under a Contract.
*Gore navedeno važi za kupce na prostoru Republike Srbije./ The aforementioned applies to purchasers of the Republic of Serbia.